

LINTECH[®]

Mechanical Motion Solutions

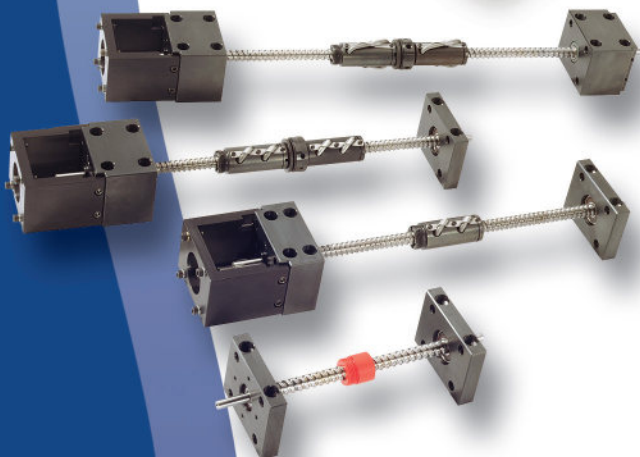

Welcome to *LINTECH*®

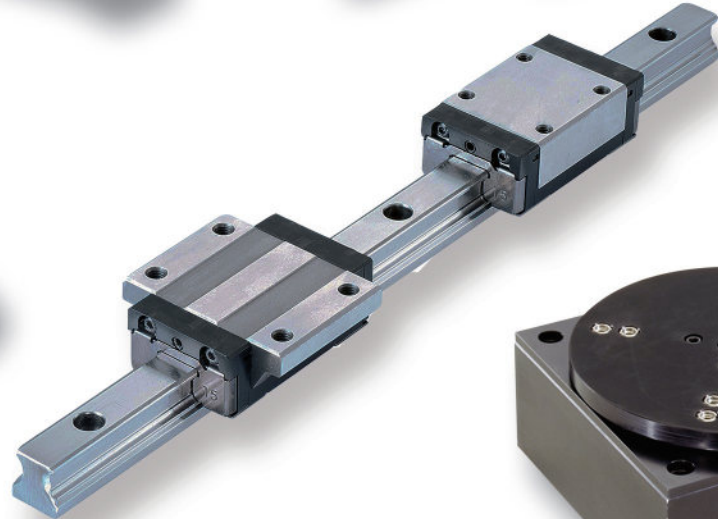
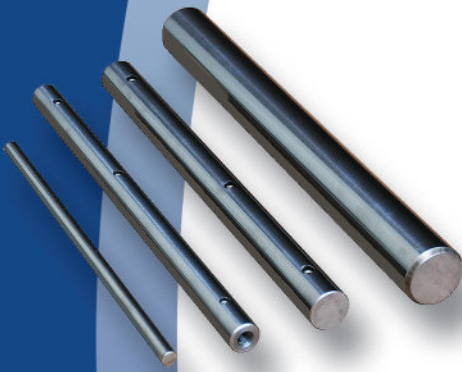
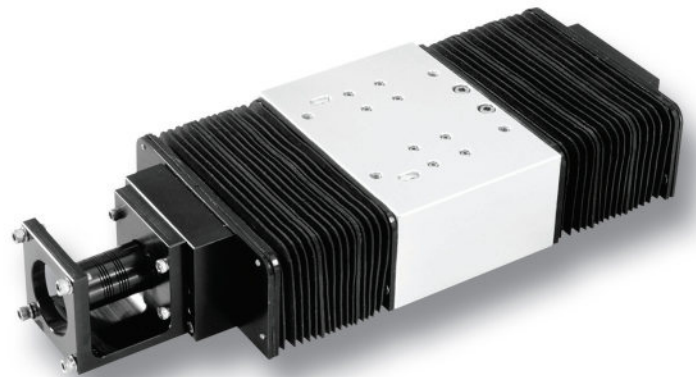
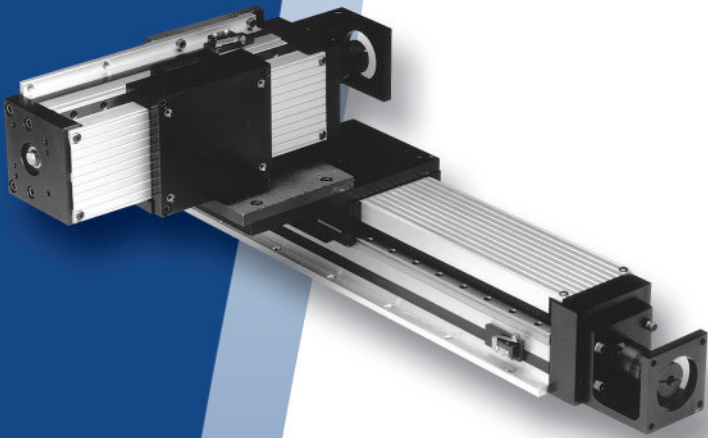

For over 47 years *LINTECH* has designed, engineered, and manufactured mechanical motion solutions for use in a wide range of applications. Whether it is a standard positioning component or a custom positioning system, *LINTECH* takes great pride in manufacturing a quality product.

At *LINTECH* we are proud to provide the motion control user with this general product guide. It was developed to assist you with acquiring the general knowledge of what *LINTECH* has to offer. You can find complete, and up to date, details on all *LINTECH* products via our website.

Depending on the requirements, standard positioning components can often be assembled and shipped in less than 2 weeks. Custom positioning systems require a different approach. We evaluate your special application, use our many years of experience to guide you, and then manufacture a quality product designed to meet your performance specifications.

LINTECH's technical support consists of a well trained inside customer service department, an experienced application engineering staff, and a versatile machining facility.

Our local technical support group consists of Automation Specialists located throughout the World. These Automation Specialists are experienced in the use of electronic and mechanical motion control products. They are well trained on the performance capabilities of *LINTECH* positioning components.

LINTECH is constantly designing new products and improving upon the many options available with our standard products. Whether it is a standard or custom positioning system required, visit our website, call, or e-mail us. We look forward to hearing from you.

Visit our website, or call us for the location of the nearest Automation Specialist in your area:

LINTECH®

1845 Enterprise Way
Monrovia, CA. 91016

Toll Free: (800) 435 - 7494

Phone: (626) 358 - 0110

Fax: (626) 303 - 2035



Web Site: www.LintechMotion.com

E-Mail: Lintech@LintechMotion.com

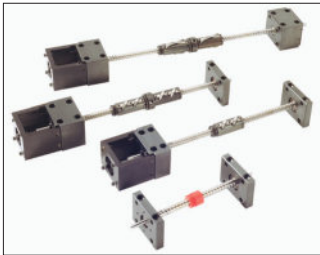
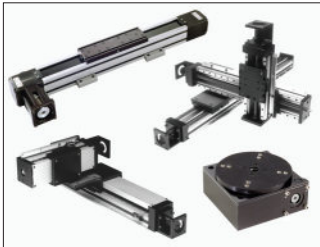

version: 07/2018

Table of Contents

	Pages
Mechanical Components	
	
Precision Shafting	4 - 6
Shaft Supports	7 - 9
Shaft Assemblies	10 - 11
Linear Bearings - Inch	12 - 19
Carriage Assemblies	20 - 21
Linear Bearings - Metric	22 - 25
Profile Rail Linear Guides	26 - 41
Ball Screw Assemblies	
	
Overview	42
RS - Rolled Series	43 - 47
PS - Precision Series	48 - 49
GS - Ground Series	50 - 51
Standard Positioning Actuators	
	
Screw Driven	52 - 69
Belt Driven	70 - 79
Rotary Tables	80 - 81
Custom Positioning Systems	
	
Multi-Axis Systems	82 - 83
Application Guide	84 - 85
Examples	86 - 87

About this Brochure

This brochure is intended to provide a general overview on all the products available from **LINTECH**. There is some technical information given on each product that can assist with the selection of a product for a given application. Please visit our website at www.LintechMotion.com for complete technical specifications, available options, CAD drawings, and pricing.

Standard Positioning Components



LINTECH manufactures a wide range of standard round rail and square rail linear guide positioning components. The products available include: cut to length precision hardened steel shafting, shaft supports, shaft assemblies, linear bearings (with or without pillow blocks), and carriage assemblies in both inch and metric versions. The wide array of options include: chrome plated shafts, shaft machining per the user print, all steel bearings, and bearing locks. Multiple profile rail linear bearing versions are also available in any cut to length requirements.

Standard Ball Screw Assemblies

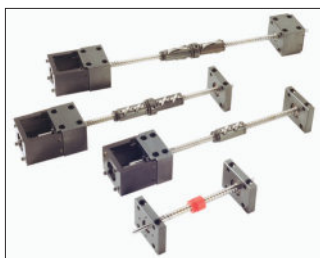

LINTECH manufactures a wide range of standard ball screw assemblies. These assemblies allow the user to get a complete, ready to mount ball screw system with end supports and nut flanges. The 3 different ball screw thread accuracy grades are rolled, precision rolled, and precision ground. The support housings are made of precision machined steel and are available in 5 configurations: simple-simple, fixed (low thrust)-simple, fixed (high thrust)-simple, rigid-simple, and rigid-rigid. There are many inch & metric screw diameter and leads available, along with motor mounts, brakes, and encoder options.

Standard Positioning Systems

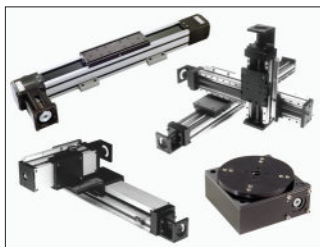

LINTECH manufactures a wide range of standard linear and rotary positioning systems. There are 9 screw driven linear slide systems, 5 belt driven linear slide systems, and 2 worm gear driven rotary positioning systems. Each system has a different load capacity, envelope size, and numerous options available to make a standard system into a semi-custom.

Custom Components and Systems



LINTECH has the ability to make alterations to any of its standard products. These changes include special lengths, special platings, unique materials, rail & screw covers or special lubricants for different environments. **LINTECH** also has the ability to start from scratch and build one of a kind custom mechanical positioning systems. Common system configurations include master-slave gantries, multi-axis configurations, wide base systems, long travel lengths, heavier load capacities, high speeds, etc.. Custom systems can be provide with stress relieved steel bases, flexible aluminum bases, or precision granite bases.

LINTECH Website

Please visit our website at www.LintechMotion.com for complete technical specifications, dimensions, available options, CAD drawings, and pricing.

The screenshot shows the Lintech website interface. At the top, there are navigation tabs: "My Account", "About Us", "Products", "Customer Service", and "Technical Support". The "Products" tab is active, showing the "170 series" product overview. A sidebar on the left contains a login form, contact information for Lintech (1845 Enterprise Way, Monrovia, CA 91016), and a "Secure Area" with a login button. The main content area displays the "Product Overview" for the 170 series, listing key features and specifications:

- Model Number:** 170 series
- Key Feature:** Large load capacity at an economical price
- Linear Bearing:** Square Rail
- Drive Type:** Acme Screw or Ball Screw
- Height:** 2.953 in (75 mm)
- Width:** 6.000 in (152 mm)
- Load Capacity:** 8,400 lbs (3810 kg)
- Travel Range:** 6 to 60 in (150 to 1520 mm)
- Top Speed:** < 60 in/sec (1270 mm/sec)
- Mounting:** English or Metric
- Delivery:** 2 to 4 weeks

Below the overview, there are sections for "Part Number" (listing CP0, CP1, CP2, WC1 for 6 inch and 12 inch carriages), "Table Material", "Screw Material", "Straightness", "Flatness", "Orthogonality", "Friction Coefficient", "Motor Mount", "Coupling", and "Waycover Material".

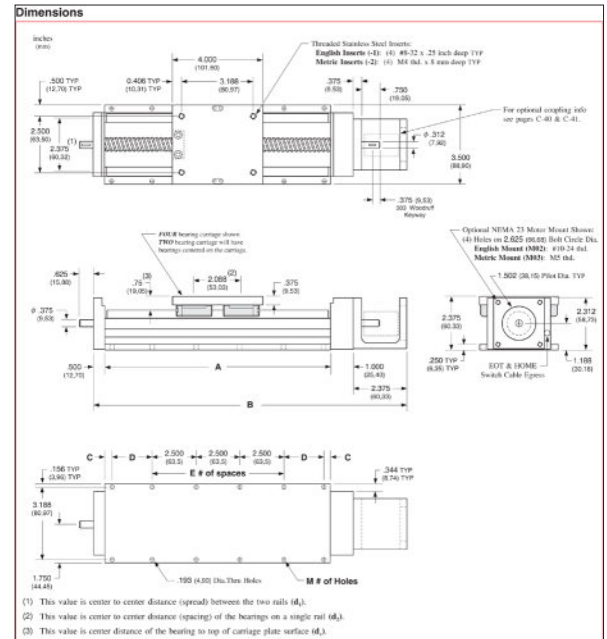

LINTECH CAD Files

The LINTeCH website is also equipped with a Part Builder that allows for the modeling of standard products in any of 36 different CAD file formats. [Get a CAD File](#)

The screenshot shows the Lintech Part Builder interface. It features a navigation bar with the Lintech logo and a "Select:" button. Below the navigation bar, there are several dropdown menus and input fields for configuring the product:

- Table Series:** 17
- Carriage Length:** 6 inches
- Number of Bearings (per carriage):** 4 - 4 bearings per carriage
- Cover Plate:** CP1 - top cover plate only
- Travel Length (in (mm)):** 18 (455)
- Carriage Inserts:** 1 - English Mount
- Screw Options:** Rolled Ball Screws
- Screw Size Options:** S005 - 525 X 210 MPL
- Motor Mount:** M02 - NEMA 23 mount (E)
- Coupling Options:** C000 - none
- EOT and Home Switches:** L00 - no switches
- Encoder Options:** E00 - none
- Brake Options:** B00 - none

A central 3D model of the linear rail is displayed, and a "Generate" button is located at the bottom left. The part number "174618 - CP1 - 1 - S005 - M02 - C000 - L00 - E00 - B00" is shown in a text box.



[More Information via the Web](#)

Dimensions & Specifications: SL, SS & SN Shafting

Model Number	Nominal Shaft Diameter (inches)	Maximum Length				Shaft Weight (lbs/in)
		SL (inches)		SS (inches)		
		-SS	-SS	-SS	-SS	
Sx4	0.250	96	144	96	144	0.014
Sx6	0.375	172	154	172	154	0.031
Sx8	0.500	184	154	184	154	0.055
Sx10	0.625	184	154	184	154	0.086
Sx12	0.750	184	154	184	154	0.125
Sx16	1.000	184	154	184	154	0.222
Sx20	1.250	184	154	184	154	0.348
Sx24	1.500	184	154	184	154	0.500
Sx32	2.000	184	154	184	154	0.890

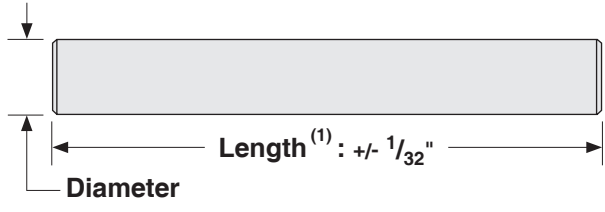

(1) Length tolerance for 2" diameter shafting is +/- 1/16 inches. Tighter tolerance available. Contact the factory.

Specifications: SL, SS & SN Shafting

Shaft Straightness	0.001/0.002 in/ft, cumulative
Shaft Type	1060 Steel or 440C Stainless steel (only with L & S tolerance)
Shaft Roundness	0.000080 inches
Shaft Chamfer	For 0.25 - 0.75 inch dia. : 0.03 inch x 45°, For 1.00 - 2.00 inch dia. : 0.06 inch x 45°
Surface Finish	8 R _a microinch
Diameter Tolerance	
Hardness Depth	

Nominal Shaft Diameter (inches)	Class L Diameter Tolerance (inches)	Class S Diameter Tolerance (inches)	Class N Diameter Tolerance (inches)	Minimum Hardness Depth (inches)
0.250	.2495 / .2490	.2490 / .2485	.2500 / .2498	0.027
0.375	.3745 / .3740	.3740 / .3735	.3750 / .3748	0.027
0.500	.4995 / .4990	.4990 / .4985	.5000 / .4998	0.040
0.625	.6245 / .6240	.6240 / .6235	.6250 / .6248	0.040
0.750	.7495 / .7490	.7490 / .7485	.7500 / .7498	0.060
1.000	.9995 / .9990	.9990 / .9985	1.0000 / .9998	0.080
1.250	1.2495 / 1.2490	1.2490 / 1.2485	1.2500 / 1.2498	0.080
1.500	1.4994 / 1.4989	1.4989 / 1.4984	1.5000 / 1.4997	0.080
2.000	1.9994 / 1.9987	1.9987 / 1.9980	2.0000 / 1.9997	0.100

[More Information via the Web](#)



Dimensions & Specifications: SL-PD Shafting

Model Number	Nominal Shaft Diameter (inches)	Maximum Length (inches)		Pre-Drilled Holes (inches)			Shaft Weight (lbs/in)
		-SS	+/- .016	A	B	G	
SL8-PD	0.500	172	154	2.00	4.00	#6-32	0.055
SL10-PD	0.625	184	154	2.00	4.00	#8-32	0.086
SL12-PD	0.750	184	154	3.00	6.00	#10-32	0.125
SL16-PD	1.000	184	154	3.00	6.00	1/4-20	0.222
SL20-PD	1.250	184	154	3.00	6.00	5/16-18	0.348
SL24-PD	1.500	184	154	4.00	8.00	3/8-16	0.500
SL32-PD	2.000	184	154	4.00	8.00	1/2-13	0.890

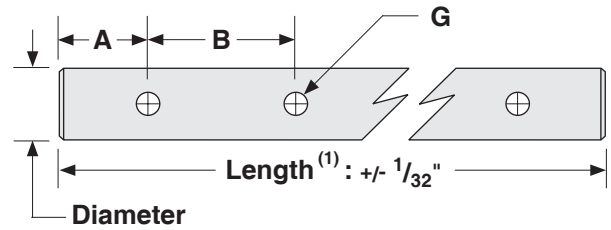

(1) Length tolerance for 2" diameter shafting is +/- 1/16 inches. Tighter tolerance available. Contact the factory.

[More Information via the Web](#)



Specifications: SM Metric Shafting

Shaft Straightness	0,0254/0,0508 mm/300 mm - cumulative																														
Shaft Type	1060 Steel																														
Shaft Roundness	0,0020 mm																														
Shaft Chamfer	For 8 - 20 mm dia. : 0,762 mm x 45°, For 25 - 50 mm dia. : 1,524 mm inch x 45°																														
Surface Finish	8 R _a microinch																														
Diameter Tolerance	<table border="1"> <thead> <tr> <th>Nominal Shaft Diameter (mm)</th> <th>Diameter Tolerance (mm)</th> <th>Minimum Hardness Depth (mm)</th> </tr> </thead> <tbody> <tr><td>8</td><td>8,00 / 7,99</td><td>0,69</td></tr> <tr><td>10</td><td>10,00 / 9,99</td><td>0,69</td></tr> <tr><td>12</td><td>12,00 / 11,99</td><td>1,02</td></tr> <tr><td>16</td><td>16,00 / 15,99</td><td>1,02</td></tr> <tr><td>20</td><td>20,00 / 19,99</td><td>1,52</td></tr> <tr><td>25</td><td>25,00 / 24,99</td><td>2,03</td></tr> <tr><td>30</td><td>30,00 / 29,99</td><td>2,03</td></tr> <tr><td>40</td><td>40,00 / 39,99</td><td>2,03</td></tr> <tr><td>50</td><td>50,00 / 49,98</td><td>2,54</td></tr> </tbody> </table>	Nominal Shaft Diameter (mm)	Diameter Tolerance (mm)	Minimum Hardness Depth (mm)	8	8,00 / 7,99	0,69	10	10,00 / 9,99	0,69	12	12,00 / 11,99	1,02	16	16,00 / 15,99	1,02	20	20,00 / 19,99	1,52	25	25,00 / 24,99	2,03	30	30,00 / 29,99	2,03	40	40,00 / 39,99	2,03	50	50,00 / 49,98	2,54
Nominal Shaft Diameter (mm)		Diameter Tolerance (mm)	Minimum Hardness Depth (mm)																												
8		8,00 / 7,99	0,69																												
10		10,00 / 9,99	0,69																												
12		12,00 / 11,99	1,02																												
16		16,00 / 15,99	1,02																												
20		20,00 / 19,99	1,52																												
25		25,00 / 24,99	2,03																												
30		30,00 / 29,99	2,03																												
40		40,00 / 39,99	2,03																												
50	50,00 / 49,98	2,54																													
Hardness Depth																															

Dimensions & Specifications: SM Metric Shafting

Model Number	Nominal Shaft Diameter (mm)	Maximum Length inches (mm)	Shaft Weight (lbs/in)
SM8	8	172 (4368,8)	0.022
SM10	10	172 (4368,8)	0.038
SM12	12	184 (4673,6)	0.050
SM16	16	184 (4673,6)	0.088
SM20	20	184 (4673,6)	0.138
SM25	25	184 (4673,6)	0.216
SM30	30	184 (4673,6)	0.311
SM40	40	184 (4673,6)	0.553
SM50	50	184 (4673,6)	0.864

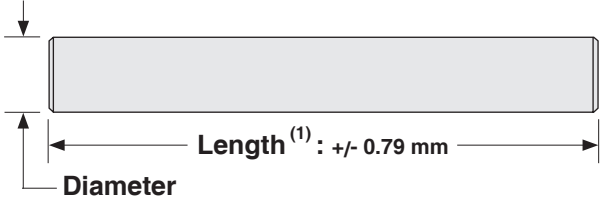

(1) Tighter tolerance available. Contact the factory.

[More Information via the Web](#)

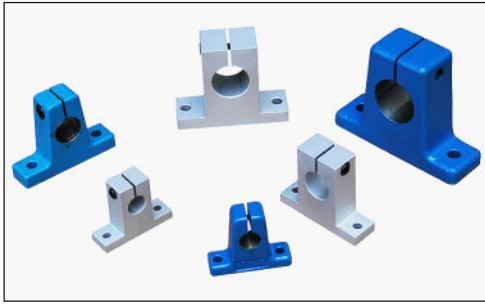

Dimensions & Specifications: ES-A End Support Block

Model Number	Nominal Shaft Diameter (inches)	Dimensions (inches)									Support Weight (lbs)
		A +/- .001	B	C	D	E +/- .010	F	H	M		
									hole	bolt size	
ES8-A	0.500	1.000	2.000	0.875	.250	1.500	0.625	1.625	.188	#8	.08
ES10-A	0.625	1.000	2.500	1.250	.313	1.750	0.688	1.875	.218	#10	.11
ES12-A	0.750	1.250	2.500	1.250	.313	2.000	0.750	2.063	.218	#10	.16
ES16-A	1.000	1.500	3.063	1.500	.375	2.500	1.000	2.500	.281	1/4	.30
ES20-A	1.250	1.750	3.750	2.000	.438	3.000	1.125	3.000	.346	5/16	.53
ES24-A	1.500	2.000	4.375	2.250	.500	3.500	1.250	3.437	.346	5/16	.73
ES32-A	2.000	2.500	5.500	3.000	.625	4.500	1.500	4.500	.406	3/8	1.40

Material:
6061-T6 aluminum
Natural Finish

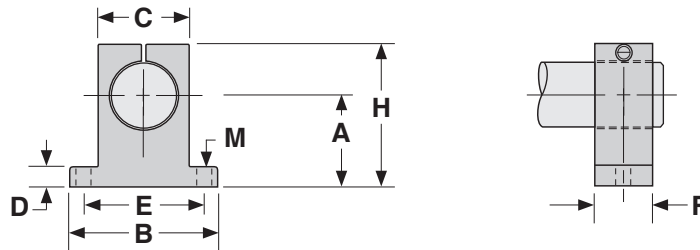

Dimensions & Specifications: ES-S End Support Block

Model Number	Nominal Shaft Diameter (inches)	Dimensions (inches)									Support Weight (lbs)
		A +/- .001	B	C	D	E +/- .010	F	H	M		
									hole	bolt size	
ES8-S	0.500	1.000	2.000	0.750	.250	1.500	0.625	1.625	.218	#10	.28
ES10-S	0.625	1.000	2.500	0.875	.312	1.875	0.750	1.750	.218	#10	.36
ES12-S	0.750	1.250	2.750	1.000	.375	2.000	0.750	2.125	.281	1/4	.53
ES16-S	1.000	1.500	3.312	1.375	.375	2.500	1.000	2.625	.281	1/4	1.00
ES20-S	1.250	1.750	4.000	1.750	.438	3.000	1.250	3.000	.343	5/16	2.10
ES24-S	1.500	2.000	4.750	2.000	.500	3.500	1.250	3.500	.343	5/16	2.80
ES32-S	2.000	2.500	6.000	2.625	.625	4.500	1.500	4.500	.406	3/8	5.10

Material:
C1045 steel
Blue Enamel

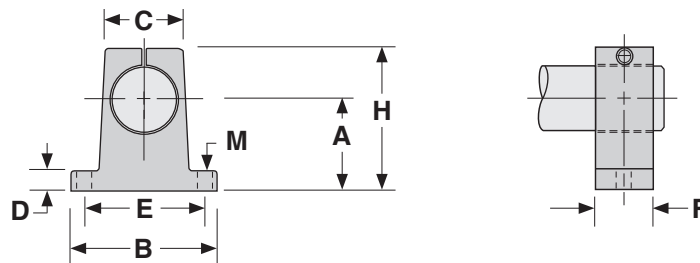

[More Information via the Web](#)



Dimensions & Specifications: ARS-PD Shaft Support

Model Number		Nominal Shaft Diameter (inches)	Dimensions (inches)									Support Weight (lbs/in)
Without Holes	With Predrilled Holes		A +/- .002	B	C	D	E +/- .010	F hole	G bolt size	H	I	
ARS8	ARS8-PD	0.500	1.125	1.500	.250	.187	1.000	.169	#6-32 x 0.87	2.00	4.00	.050
ARS10	ARS10-PD	0.625	1.125	1.625	.312	.250	1.125	.193	#8-32 x 0.87	2.00	4.00	.063
ARS12	ARS12-PD	0.750	1.500	1.750	.375	.250	1.250	.221	#10-32 x 1.25	3.00	6.00	.083
ARS16	ARS16-PD	1.000	1.750	2.125	.500	.250	1.500	.281	1/4-20 x 1.50	3.00	6.00	.108
ARS20	ARS20-PD	1.250	2.125	2.500	.562	.312	1.875	.343	5/16-18 x 1.75	3.00	6.00	.146
ARS24	ARS24-PD	1.500	2.500	3.000	.687	.375	2.250	.406	3/8-16 x 2.00	4.00	8.00	.213
ARS32	ARS32-PD	2.000	3.250	3.750	.875	.500	2.750	.531	1/2-13 x 3.25	4.00	8.00	.342

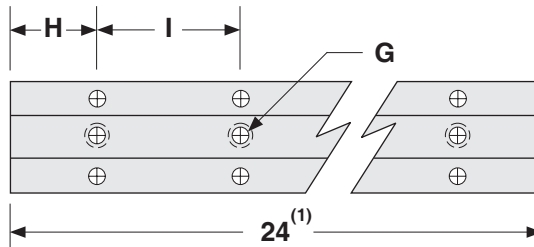
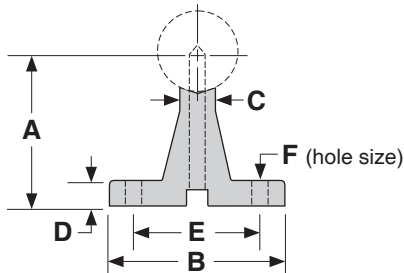

(1) Shorter lengths available. Contact the factory.

Material: 6061-T6 aluminum, Natural Finish

[More Information via the Web](#)



Dimensions & Specifications: LSRS-PD Shaft Support

Model Number		Nominal Shaft Diameter (inches)	Dimensions (inches)							Support Weight (lbs/in)
Without Holes	With Predrilled Holes		A +/- .002	B	C	G		H	I	
						hole	bolt size			
LSRS8	LSRS8-PD	0.500	0.562	0.37	.341	.169	#6-32	2.00	4.00	.028
LSRS10	LSRS10-PD	0.625	0.687	0.45	.412	.193	#8-32	2.00	4.00	.041
LSRS12	LSRS12-PD	0.750	0.750	0.51	.420	.221	#10-32	3.00	6.00	.047
LSRS16	LSRS16-PD	1.000	1.000	0.69	.560	.281	1/4-20	3.00	6.00	.089
LSRS20	LSRS20-PD	1.250	1.187	0.78	.626	.343	5/16-18	3.00	6.00	.106
LSRS24	LSRS24-PD	1.500	1.375	0.93	.703	.406	3/8-16	4.00	8.00	.140
LSRS32	LSRS32-PD	2.000	1.750	1.18	.845	.531	1/2-13	4.00	8.00	.230

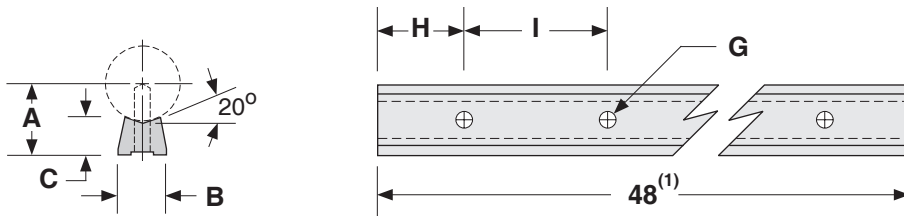

(1) Shorter lengths available. Contact the factory.

Material: AISI C-1018 steel, Natural Finish

[More Information via the Web](#)



Specifications: SA Shaft Assemblies

Support Type & Finish	Precision Machined 6061-T6 Aluminum, Black Anodized																								
Shaft Straightness	0.001/0.002 in/ft, cumulative																								
Shaft Type	SL - 1060 Steel or 440C Stainless steel																								
Shaft Roundness	0.000080 inches																								
Shaft Chamfer	For 0.50 - 0.75 inch dia. : 0.03 inch x 45°, For 1.00 - 2.00 inch dia. : 0.06 inch x 45°																								
Surface Finish	8 - 12 R _a microinch																								
Diameter Tolerance	<table border="1"> <thead> <tr> <th>Nominal Shaft Diameter (inches)</th> <th>Shaft Diameter Tolerance (inches)</th> <th>Minimum Hardness Depth (inches)</th> </tr> </thead> <tbody> <tr> <td>0.500</td> <td>.4995 / .4990</td> <td>0.040</td> </tr> <tr> <td>0.625</td> <td>.6245 / .6240</td> <td>0.040</td> </tr> <tr> <td>0.750</td> <td>.7495 / .7490</td> <td>0.060</td> </tr> <tr> <td>1.000</td> <td>.9995 / .9990</td> <td>0.080</td> </tr> <tr> <td>1.250</td> <td>1.2495 / 1.2490</td> <td>0.080</td> </tr> <tr> <td>1.500</td> <td>1.4994 / 1.4989</td> <td>0.080</td> </tr> <tr> <td>2.000</td> <td>1.9994 / 1.9987</td> <td>0.100</td> </tr> </tbody> </table>	Nominal Shaft Diameter (inches)	Shaft Diameter Tolerance (inches)	Minimum Hardness Depth (inches)	0.500	.4995 / .4990	0.040	0.625	.6245 / .6240	0.040	0.750	.7495 / .7490	0.060	1.000	.9995 / .9990	0.080	1.250	1.2495 / 1.2490	0.080	1.500	1.4994 / 1.4989	0.080	2.000	1.9994 / 1.9987	0.100
Nominal Shaft Diameter (inches)		Shaft Diameter Tolerance (inches)	Minimum Hardness Depth (inches)																						
0.500		.4995 / .4990	0.040																						
0.625		.6245 / .6240	0.040																						
0.750		.7495 / .7490	0.060																						
1.000		.9995 / .9990	0.080																						
1.250		1.2495 / 1.2490	0.080																						
1.500		1.4994 / 1.4989	0.080																						
2.000	1.9994 / 1.9987	0.100																							
Hardness Depth																									

Model Number	Nominal Shaft Diameter (inches)	Dimensions (inches)						
		A +/- .002	B	C	D	E +/- .010	F hole	G bolt size
SA8	0.500	1.125	1.500	.250	.187	1.000	.169	#6-32
SA10	0.625	1.125	1.625	.312	.250	1.125	.193	#8-32
SA12	0.750	1.500	1.750	.375	.250	1.250	.221	#10-32
SA16	1.000	1.750	2.125	.500	.250	1.500	.281	1/4-20
SA20	1.250	2.125	2.500	.562	.312	1.875	.281	1/4-20
SA24	1.500	2.500	3.000	.687	.375	2.250	.343	5/16-18
SA32	2.000	3.250	3.750	.875	.500	2.750	.406	3/8-16

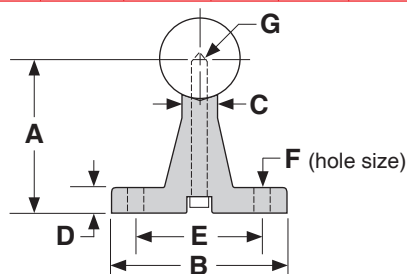

Standard lengths to 16 feet (192 inches). Longer lengths available - Contact Factory.

[More Information via the Web](#)



Specifications: TRSA TWIN RAIL® Shaft Assemblies

Support Type & Finish	Precision Machined 6061-T6 Aluminum, Black Anodized																								
Shaft Straightness	0.001/0.002 in/ft, cumulative																								
Shaft Parallelism	+/- 0.002 in overall																								
Shaft Type	SL - 1060 Steel or 440C Stainless steel																								
Shaft Roundness	0.000080 inches																								
Shaft Chamfer	For 0.50 - 0.75 inch dia. : 0.03 inch x 45°, For 1.00 - 2.00 inch dia. : 0.06 inch x 45°																								
Surface Finish	8 - 12 R _a microinch																								
Diameter Tolerance	<table border="1"> <thead> <tr> <th>Nominal Shaft Diameter (inches)</th> <th>Shaft Diameter Tolerance (inches)</th> <th>Minimum Hardness Depth (inches)</th> </tr> </thead> <tbody> <tr> <td>0.500</td> <td>.4995 / .4990</td> <td>0.040</td> </tr> <tr> <td>0.625</td> <td>.6245 / .6240</td> <td>0.040</td> </tr> <tr> <td>0.750</td> <td>.7495 / .7490</td> <td>0.060</td> </tr> <tr> <td>1.000</td> <td>.9995 / .9990</td> <td>0.080</td> </tr> <tr> <td>1.250</td> <td>1.2495 / 1.2490</td> <td>0.080</td> </tr> <tr> <td>1.500</td> <td>1.4994 / 1.4989</td> <td>0.080</td> </tr> <tr> <td>2.000</td> <td>1.9994 / 1.9987</td> <td>0.100</td> </tr> </tbody> </table>	Nominal Shaft Diameter (inches)	Shaft Diameter Tolerance (inches)	Minimum Hardness Depth (inches)	0.500	.4995 / .4990	0.040	0.625	.6245 / .6240	0.040	0.750	.7495 / .7490	0.060	1.000	.9995 / .9990	0.080	1.250	1.2495 / 1.2490	0.080	1.500	1.4994 / 1.4989	0.080	2.000	1.9994 / 1.9987	0.100
Nominal Shaft Diameter (inches)		Shaft Diameter Tolerance (inches)	Minimum Hardness Depth (inches)																						
0.500		.4995 / .4990	0.040																						
0.625		.6245 / .6240	0.040																						
0.750		.7495 / .7490	0.060																						
1.000		.9995 / .9990	0.080																						
1.250		1.2495 / 1.2490	0.080																						
1.500		1.4994 / 1.4989	0.080																						
2.000	1.9994 / 1.9987	0.100																							
Hardness Depth																									

Model Number	Nominal Shaft Diameter (inches)	Dimensions (inches)										
		A +/- .002	B +/- .002	C	D	E +/- .010	F	G	H	J hole	K Bolt Size	L ⁽¹⁾ Thread
TRSA8	0.500	1.125	3.000	3.750	0.875	2.000	.375	.312	.250	.169	#6-32	#10-32
TRSA10	0.625	1.125	3.750	4.625	1.000	2.625	.437	.312	.312	.193	#8-32	#10-32
TRSA12	0.750	1.500	4.500	5.500	1.125	3.250	.500	.312	.375	.221	#10-32	#10-32
TRSA16	1.000	1.750	5.250	6.375	1.312	3.750	.562	.312	.500	.281	1/4-20	#10-32
TRSA20	1.250	2.125	6.000	7.250	1.562	4.125	.625	.375	.562	.281	1/4-20	1/4-20
TRSA24	1.500	2.500	6.625	8.125	1.875	4.375	.750	.437	.687	.343	5/16-18	5/16-18
TRSA32	2.000	3.250	7.250	9.000	2.250	4.500	.875	.562	.875	.406	3/8-16	3/8-16

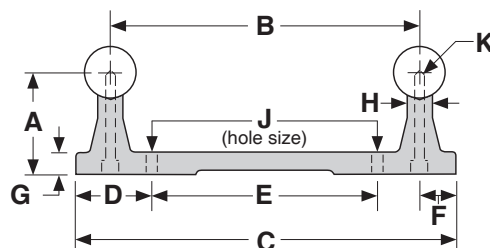

(1) Two threaded leveling holes per support segment are used for setscrew adjustment to aid in assembly leveling user mounting surfaces. Standard lengths to 16 feet (192 inches). Longer lengths available - Contact Factory.

[More Information via the Web](#)



Specifications: LBCA & LBOA Linear Bearings

Operating Temperature Maximum Speed Bearing Seals (optional) Matching Shaft	0° F to + 600° F (LBCA series without seals) 0° F to + 185° F (all other models) 10 ft/second Internal Wiper Seals on both ends, Plastic Bearing Retainer Class S (SS series), hardened & ground shafting (see pages 4 & 5)				
Housing Tolerances C = clearance	LBCA (closed style)			LBOA (open style)	
	Nominal Shaft Diameter (inches)	Recommended Housing Bore		Bearing and Shaft Fit-up (inches)	Nominal Shaft Diameter (inches)
		Normal Fit (inches)	Press Fit (inches)		Recommended Housing Bore before adjustment (inches)
	0.250	.5005 / .5000	.4995 / .4990	.0015C / .0005C	
	0.375	.6255 / .6250	.6245 / .6240	.0015C / .0005C	
	0.500	.8755 / .8750	.8745 / .8740	.0015C / .0005C	0.500
	0.625	1.1255 / 1.1250	1.1245 / 1.1240	.0015C / .0005C	0.625
	0.750	1.2505 / 1.2500	1.2495 / 1.2490	.0015C / .0005C	0.750
	1.000	1.5630 / 1.5625	1.5620 / 1.5615	.0015C / .0005C	1.000
	1.250	2.0010 / 2.0000	1.9993 / 1.9983	.0015C / .0004C	1.250
	1.500	2.3760 / 2.3750	2.3743 / 2.3733	.0016C / .0005C	1.500
	2.000	3.0010 / 3.0000	2.9992 / 2.9982	.0020C / .0005C	2.000

Dimensions & Specifications: **LBCA** Precision Linear Bearing (closed)

Model Number		Nominal Shaft Diameter (inches)	Working Bore Diameter (inches)	Dyn. ⁽¹⁾ Load Capacity (lbs)	Dimensions (inches)				Bearing Weight (lbs)
Without Seals	With ⁽²⁾ Seals				A	B	C	D	
LBCA-4	LBCA-4-S	0.250	0.2500/0.2495	19	0.750/0.735	0.515/0.499	0.039	0.5000/0.4996	0.02
LBCA-6	LBCA-6-S	0.375	0.3750/0.3745	37	0.875/0.860	0.640/0.624	0.039	0.6250/0.6246	0.06
LBCA-8	LBCA-8-S	0.500	0.5000/0.4995	85	1.250/1.235	0.967/0.951	0.046	0.8750/0.8746	0.08
LBCA-10	LBCA-10-S	0.625	0.6250/0.6245	150	1.500/1.485	1.108/1.092	0.056	1.1250/1.1246	0.16
LBCA-12	LBCA-12-S	0.750	0.7500/0.7495	200	1.625/1.610	1.170/1.154	0.056	1.2500/1.2496	0.21
LBCA-16	LBCA-16-S	1.000	1.0000/0.9995	350	2.250/2.235	1.759/1.741	0.068	1.5625/1.5621	0.38
LBCA-20	LBCA-20-S	1.250	1.2500/1.2494	520	2.625/2.605	2.009/1.991	0.068	2.0000/1.9995	1.10
LBCA-24	LBCA-24-S	1.500	1.5000/1.4994	770	3.000/2.980	2.415/2.397	0.086	2.3750/2.3745	1.43
LBCA-32	LBCA-32-S	2.000	2.0000/1.9992	1,100	4.000/3.980	3.195/3.177	0.103	3.0000/2.9994	2.75

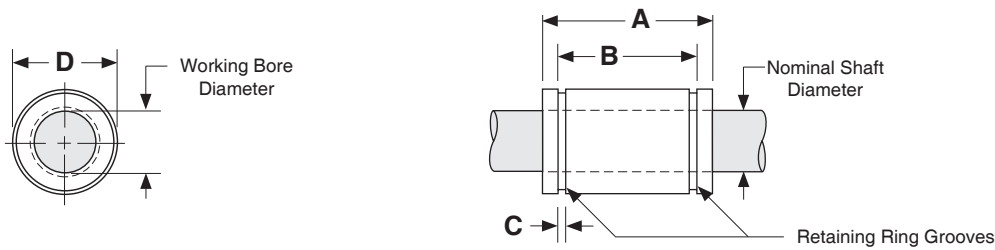

Dimensions & Specifications: **LBOA** Precision Linear Bearing (open)

Model Number		Nominal Shaft Diameter (inches)	Working Bore Diameter (inches)	Dyn. ⁽¹⁾ Load Capacity (lbs)	Dimensions (inches)					Bearing Weight (lbs)
Without Seals	With ⁽²⁾ Seals				A	B	C	D	E min.	
LBOA-8	LBOA-8-S	0.500	0.5005/0.4995	60	1.250/1.235	0.967/0.951	0.046	0.8760/0.8746	0.31	0.07
LBOA-10	LBOA-10-S	0.625	0.6255/0.6245	105	1.500/1.485	1.108/1.092	0.056	1.1260/1.1240	0.38	0.11
LBOA-12	LBOA-12-S	0.750	0.7505/0.7495	140	1.625/1.610	1.170/1.154	0.056	1.2510/1.2490	0.44	0.17
LBOA-16	LBOA-16-S	1.000	1.0005/0.9995	240	2.250/2.235	1.759/1.741	0.068	1.5635/1.5615	0.56	0.32
LBOA-20	LBOA-20-S	1.250	1.2506/1.2494	400	2.625/2.605	2.009/1.991	0.068	2.0010/1.9990	0.63	0.90
LBOA-24	LBOA-24-S	1.500	1.5006/1.4994	600	3.000/2.980	2.415/2.397	0.086	2.3760/2.3740	0.75	1.12
LBOA-32	LBOA-32-S	2.000	2.0008/1.9992	860	4.000/3.980	3.195/3.177	0.103	3.0010/2.9990	1.00	2.16

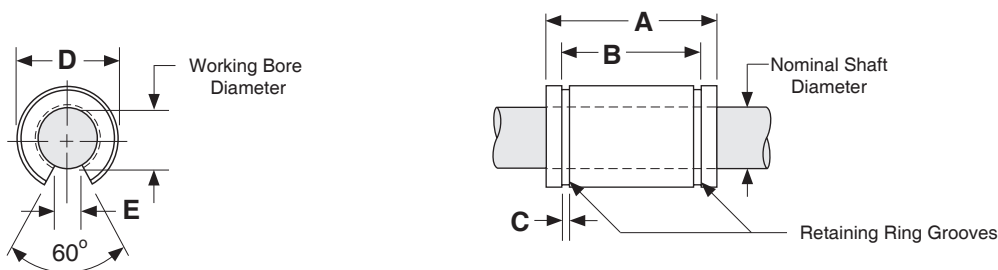

Footnotes:

- (1) Rating based upon 2 million inches of travel with the load forces being applied downward on the linear bearing, while in a horizontal application, and based upon 1060 steel shafting (Rockwell 60C).
- (2) The bearing retainer is plastic when the internal -S seal option is selected.

[More Information via the Web](#)

[More Information via the Web](#)



Specifications: LBC & LBO Linear Bearings

Operating Temperature Maximum Speed Bearing Seals Matching Shaft	<p>0° F to + 185° F</p> <p>9 ft/second</p> <p>Optional Internal Wiper Seals on both ends</p> <p>Class L (SL series), hardened & ground shafting (see pages 4 & 5)</p>				
Housing Tolerances C = clearance P = preload	Nominal Shaft Diameter (inches)	Recommended Housing Bore		Bearing and Shaft Fit-up⁽¹⁾ (before adjustment)	
		Fixed Housing (inches)	Adjustable Housing (inches)	Fixed Housing (inches)	Adjustable Housing (inches)
	0.250	.5005 / .5000	.5010 / .5000	.0015C / .0000	.002C / .0000
	0.375	.6255 / .6250	.6260 / .6250	.0015C / .0000	.002C / .0000
	0.500	.8755 / .8750	.8760 / .8750	.0015C / .0000	.002C / .0000
	0.625	1.1255 / 1.1250	1.1260 / 1.1250	.0015C / .0000	.002C / .0000
	0.750	1.2505 / 1.2500	1.2510 / 1.2500	.0015C / .0000	.002C / .0000
	1.000	1.5630 / 1.5625	1.5635 / 1.5625	.0015C / .0000	.002C / .0000
	1.250	2.0008 / 2.0000	2.0010 / 2.0000	.0018C / .0001P	.002C / .0000
	1.500	2.3760 / 2.3750	2.3760 / 2.3750	.0021C / .0000	.0021C / .0000
	2.000	3.0010 / 3.0000	3.0010 / 3.0000	.0023C / .0002P	.0023C / .0002P

(1) Adjustable Housing Diameter (before adjustment) for LBO-20 is .002C/.0001P.

Dimensions & Specifications: LBC Linear Bearing (closed)

Model Number		Nominal Shaft Diameter (inches)	Dyn. Load Capacity (lbs)	Working Bore Diameter (inches)	Housing Bore D (inches)	Dimensions (inches)			Bearing Weight (lbs)
Without Seals	With Seals					A	B	C	
LBC-4	LBC-4-S	0.250	60	0.2500/0.2495	0.5005/0.5000	0.750/0.735	0.511/0.501	0.039	0.01
LBC-6	LBC-6-S	0.375	105	0.3750/0.3745	0.6255/0.6250	0.875/0.860	0.699/0.689	0.039	0.02
LBC-8	LBC-8-S	0.500	265	0.5000/0.4995	0.8755/0.8750	1.250/1.230	1.032/1.012	0.050	0.04
LBC-10	LBC-10-S	0.625	450	0.6250/0.6245	1.1255/1.1250	1.500/1.480	1.105/1.095	0.056	0.10
LBC-12	LBC-12-S	0.750	640	0.7500/0.7495	1.2505/1.2500	1.625/1.605	1.270/1.250	0.056	0.14
LBC-16	LBC-16-S	1.000	1,050	1.0000/0.9995	1.5630/1.5625	2.250/2.230	1.884/1.864	0.068	0.25
LBC-20	LBC-20-S	1.250	1,550	1.2500/1.2494	2.0008/2.0000	2.625/2.600	2.004/1.984	0.068	0.45
LBC-24	LBC-24-S	1.500	2,000	1.5000/1.4994	2.3760/2.3750	3.000/2.970	2.410/2.390	0.086	0.85
LBC-32	LBC-32-S	2.000	3,000	2.0000/1.9992	3.0010/3.0000	4.000/3.960	3.206/3.176	0.103	1.45

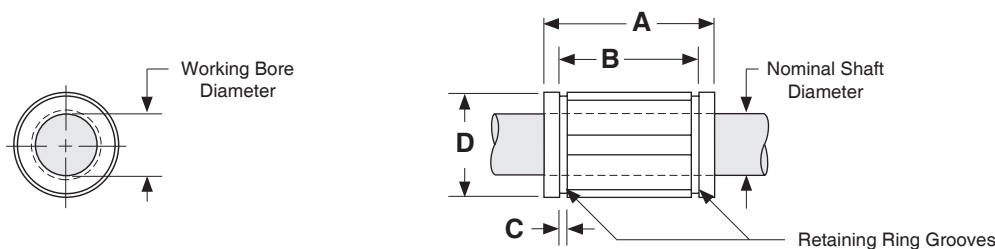

[More Information via the Web](#)

Dimensions & Specifications: LBO Linear Bearing (open)

Model Number		Nominal Shaft Diameter (inches)	Dyn. Load Cap. (lbs)	Working Bore Diameter (inches)	Housing Bore D (inches)	Dimensions (inches)				Retention Hole		Bearing Weight (lbs)
Without Seals	With Seals					A	B	C	E min.	F dia.	G (in)	
LBO-8	LBO-8-S	0.500	230	0.5000/0.4995	0.8755/0.8750	1.250/1.230	1.032/1.012	0.050	0.312	.14	.63	0.04
LBO-10	LBO-10-S	0.625	320	0.6250/0.6245	1.1255/1.1250	1.500/1.480	1.105/1.095	0.056	0.375	.11	.13	0.08
LBO-12	LBO-12-S	0.750	470	0.7500/0.7495	1.2505/1.2500	1.625/1.605	1.270/1.250	0.056	0.437	.14	.13	0.12
LBO-16	LBO-16-S	1.000	780	1.0000/0.9995	1.5630/1.5625	2.250/2.230	1.884/1.864	0.068	0.562	.14	.13	0.21
LBO-20	LBO-20-S	1.250	1,170	1.2500/1.2494	2.0008/2.0000	2.625/2.600	2.004/1.984	0.068	0.625	.20	.19	0.38
LBO-24	LBO-24-S	1.500	1,560	1.5000/1.4994	2.3760/2.3750	3.000/2.970	2.410/2.390	0.086	0.750	.20	.19	0.71
LBO-32	LBO-32-S	2.000	2,350	2.0000/1.9992	3.0010/3.0000	4.000/3.960	3.206/3.176	0.103	1.105	.27	.31	1.20

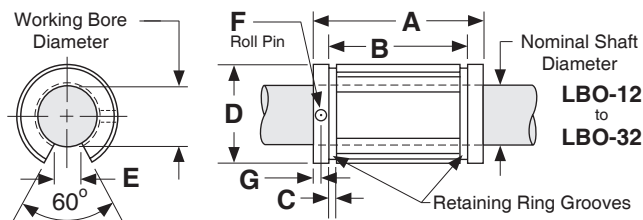
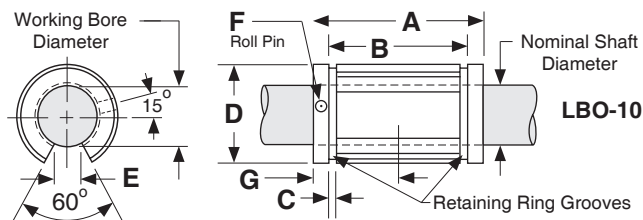
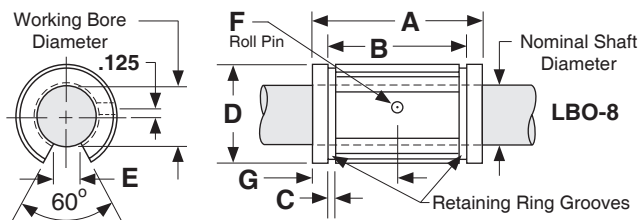

Footnotes:

- (1) Rating based upon 2 million inches of travel with the load forces being applied downward on the linear bearing, while in a horizontal application, and based upon 1060 steel shafting (Rockwell 60C).
- (2) This specification is based upon the bearing being on the shaft.

[More Information via the Web](#)

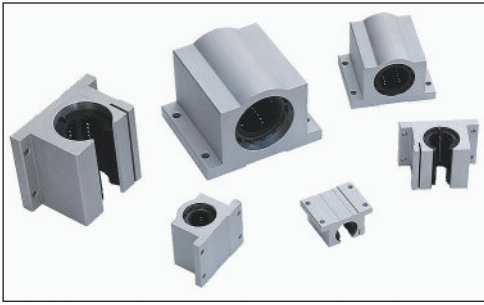

Specifications: **SLBC** & **SLBO** Pillow Blocks

<p>Bearing Housing Type & Finish Bearing Seals Bearing Type - Internal</p>	<p>Aluminum 6061-T6 Pillow Block, Natural Finish Internal Wiper Seals on Both Ends LBC or LBO series</p>																
<p>Operating Temperature Maximum Speed Matching Shaft</p>	<p>0° F to + 185° F 9 ft/second Class L (SL series), hardened & ground shafting (see pages 4 & 5)</p>																
<p>Diameter Tolerance</p>	<table border="1"> <thead> <tr> <th data-bbox="678 835 889 940"> Nominal Shaft Diameter (inches) </th> <th data-bbox="889 835 1101 940"> Shaft Diameter Tolerance (inches) </th> </tr> </thead> <tbody> <tr> <td data-bbox="678 940 889 989">0.500</td> <td data-bbox="889 940 1101 989">.4995 / .4990</td> </tr> <tr> <td data-bbox="678 989 889 1037">0.625</td> <td data-bbox="889 989 1101 1037">.6245 / .6240</td> </tr> <tr> <td data-bbox="678 1037 889 1085">0.750</td> <td data-bbox="889 1037 1101 1085">.7495 / .7490</td> </tr> <tr> <td data-bbox="678 1085 889 1134">1.000</td> <td data-bbox="889 1085 1101 1134">.9995 / .9990</td> </tr> <tr> <td data-bbox="678 1134 889 1182">1.250</td> <td data-bbox="889 1134 1101 1182">1.2495 / 1.2490</td> </tr> <tr> <td data-bbox="678 1182 889 1230">1.500</td> <td data-bbox="889 1182 1101 1230">1.4994 / 1.4989</td> </tr> <tr> <td data-bbox="678 1230 889 1278">2.000</td> <td data-bbox="889 1230 1101 1278">1.9994 / 1.9987</td> </tr> </tbody> </table>	Nominal Shaft Diameter (inches)	Shaft Diameter Tolerance (inches)	0.500	.4995 / .4990	0.625	.6245 / .6240	0.750	.7495 / .7490	1.000	.9995 / .9990	1.250	1.2495 / 1.2490	1.500	1.4994 / 1.4989	2.000	1.9994 / 1.9987
Nominal Shaft Diameter (inches)	Shaft Diameter Tolerance (inches)																
0.500	.4995 / .4990																
0.625	.6245 / .6240																
0.750	.7495 / .7490																
1.000	.9995 / .9990																
1.250	1.2495 / 1.2490																
1.500	1.4994 / 1.4989																
2.000	1.9994 / 1.9987																

Dimensions & Specifications: **SLBC** Single Linear Bearing Pillow Block (closed)

Model Number	Nominal Shaft Diameter (inches)	Dyn. Load Capacity (lbs)	Dimensions (inches)											Block Weight (lbs)
			A	B	C	D	E	F	G	H	J			
			+/- .003				+/- .010	+/- .010				hole	bolt	
SLBC-8	0.500	265	0.687	2.00	1.69	1.13	1.688	1.000	1.38	1.25	.25	.16	# 6	0.20
SLBC-10	0.625	450	0.875	2.50	1.94	1.44	2.125	1.125	1.75	1.63	.28	.19	# 8	0.50
SLBC-12	0.750	640	0.937	2.75	2.06	1.56	2.375	1.250	1.88	1.75	.31	.19	# 8	0.60
SLBC-16	1.000	1,050	1.187	3.25	2.81	1.94	2.875	1.750	2.38	2.19	.38	.22	#10	1.20
SLBC-20	1.250	1,550	1.500	4.00	3.63	2.50	3.500	2.000	3.00	2.81	.44	.22	#10	2.50
SLBC-24	1.500	2,000	1.750	4.75	4.00	2.88	4.125	2.500	3.50	3.25	.50	.28	1/4	3.80
SLBC-32	2.000	3,000	2.125	6.00	5.00	3.63	5.250	3.250	4.50	4.06	.63	.41	3/8	7.00

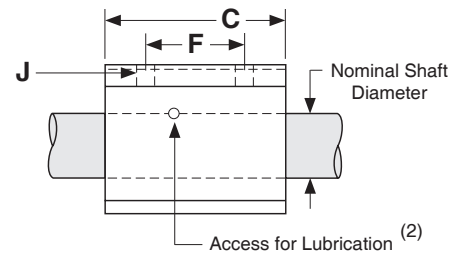
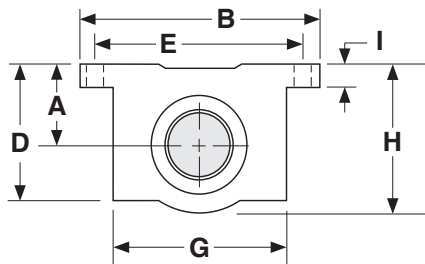

Dimensions & Specifications: **SLBO** Single Linear Bearing Pillow Block (open)

Model Number	Nominal Shaft Diameter (inches)	Dyn. Load Capacity (lbs)	Dimensions (inches)													Block Weight (lbs)
			A	B	C	D	E	F	G	H		I	J	K		
			+/- .003				+/- .010	+/- .010		hole	bolt		min.			
SLBO-8	0.500	230	0.687	2.00	1.50	1.13	1.688	1.000	0.69	.16	# 6	.25	0.31	0.75	0.20	
SLBO-10	0.625	320	0.875	2.50	1.75	1.44	2.125	1.125	0.88	.19	# 8	.28	0.37	0.94	0.40	
SLBO-12	0.750	470	0.937	2.75	1.88	1.56	2.375	1.250	0.94	.19	# 8	.31	0.43	1.00	0.50	
SLBO-16	1.000	780	1.187	3.25	2.63	2.00	2.875	1.750	1.19	.22	#10	.38	0.56	1.25	1.00	
SLBO-20	1.250	1,170	1.500	4.00	3.38	2.56	3.500	2.000	1.50	.22	#10	.44	0.62	1.63	2.10	
SLBO-24	1.500	1,560	1.750	4.75	3.75	2.94	4.125	2.500	1.75	.28	1/4	.50	0.75	1.88	3.20	
SLBO-32	2.000	2,350	2.125	6.00	4.75	3.63	5.250	3.250	2.25	.41	3/8	.63	1.00	2.44	6.00	

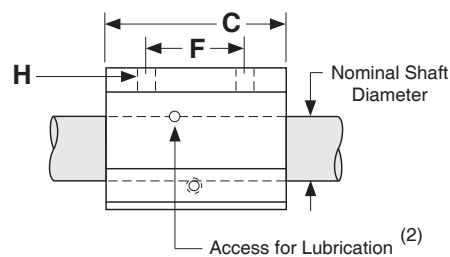
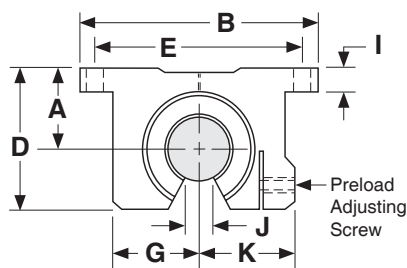

Footnotes:

(1) Rating based upon 2 million inches of travel with the load forces being applied downward on the linear bearing, while in a horizontal application, and based upon 1060 steel shafting (Rockwell 60C).

(2) Size 0.500 has oil lubricant fitting. Sizes 0.625 and above have a 1/4-28 UNF straight thread access for lubrication.

[More Information via the Web](#)

[More Information via the Web](#)

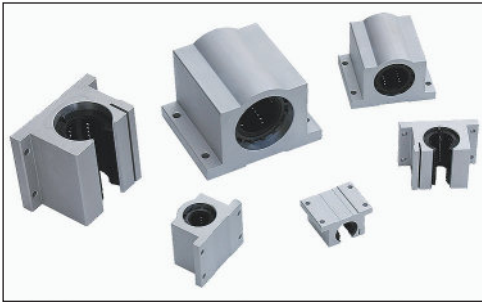

Specifications: **DLBC** & **DLBO** Pillow Blocks

Bearing Housing Type & Finish	Aluminum 6061-T6 Pillow Block, Natural Finish																	
Bearing Seals	Internal Wiper Seals on Both Ends																	
Operating Temperature	0° F to + 185° F																	
Maximum Speed	9 ft/second																	
Matching Shaft	Class L (SL series), hardened & ground shafting (see pages 4 & 5)																	
Diameter Tolerance	<table border="1"> <thead> <tr> <th>Nominal Shaft Diameter (inches)</th> <th>Shaft Diameter Tolerance (inches)</th> </tr> </thead> <tbody> <tr> <td>0.500</td> <td>.4995 / .4990</td> </tr> <tr> <td>0.625</td> <td>.6245 / .6240</td> </tr> <tr> <td>0.750</td> <td>.7495 / .7490</td> </tr> <tr> <td>1.000</td> <td>.9995 / .9990</td> </tr> <tr> <td>1.250</td> <td>1.2495 / 1.2490</td> </tr> <tr> <td>1.500</td> <td>1.4994 / 1.4989</td> </tr> <tr> <td>2.000</td> <td>1.9994 / 1.9987</td> </tr> </tbody> </table>	Nominal Shaft Diameter (inches)	Shaft Diameter Tolerance (inches)	0.500	.4995 / .4990	0.625	.6245 / .6240	0.750	.7495 / .7490	1.000	.9995 / .9990	1.250	1.2495 / 1.2490	1.500	1.4994 / 1.4989	2.000	1.9994 / 1.9987	
Nominal Shaft Diameter (inches)	Shaft Diameter Tolerance (inches)																	
0.500	.4995 / .4990																	
0.625	.6245 / .6240																	
0.750	.7495 / .7490																	
1.000	.9995 / .9990																	
1.250	1.2495 / 1.2490																	
1.500	1.4994 / 1.4989																	
2.000	1.9994 / 1.9987																	

Dimensions & Specifications: DLBC Double Linear Bearing Pillow Block (closed)

Model Number	Nominal Shaft Diameter (inches)	Dyn. Load Capacity (lbs)	Dimensions (inches)											Block Weight (lbs)	
			A	B	C	D	E	F	G	H	I	J			d ₂ ⁽³⁾
			+/- .003				+/- .010	+/- .010				hole	bolt		
DLBC-8	0.500	530	0.687	2.00	3.50	1.13	1.688	2.500	1.38	1.25	.25	.16	# 6	1.75	0.40
DLBC-10	0.625	900	0.875	2.50	4.00	1.44	2.125	3.000	1.75	1.63	.28	.19	# 8	2.00	1.00
DLBC-12	0.750	1,280	0.937	2.75	4.50	1.56	2.375	3.500	1.88	1.75	.31	.19	# 8	2.25	1.20
DLBC-16	1.000	2,100	1.187	3.25	6.00	1.94	2.875	4.500	2.38	2.19	.38	.22	#10	3.00	2.40
DLBC-20	1.250	3,100	1.500	4.00	7.50	2.50	3.500	5.500	3.00	2.81	.44	.22	#10	3.75	5.00
DLBC-24	1.500	4,000	1.750	4.75	9.00	2.88	4.125	6.500	3.50	3.25	.50	.28	1/4	4.50	7.80
DLBC-32	2.000	6,000	2.125	6.00	10.00	3.63	5.250	8.250	4.50	4.06	.63	.41	3/8	5.75	14.50

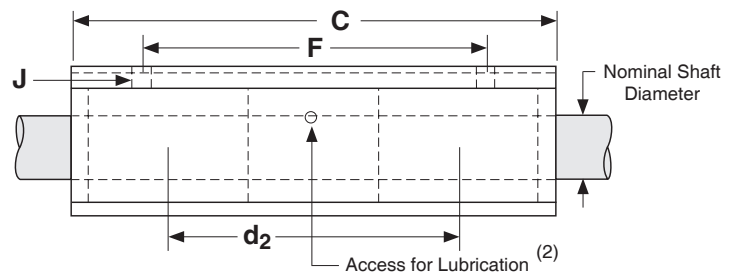
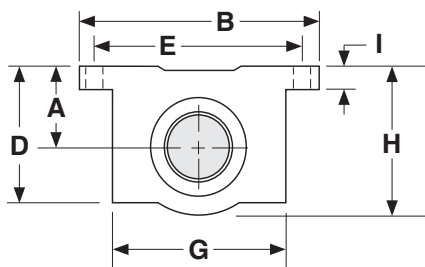

Dimensions & Specifications: DLBO Double Linear Bearing Pillow Block (open)

Model Number	Nominal Shaft Diameter (inches)	Dyn. Load Capacity (lbs)	Dimensions (inches)													Block Weight (lbs)
			A	B	C	D	E	F	G	H	I	J		K	d ₂ ⁽³⁾	
			+/- .003				+/- .010	+/- .010		min.		hole	bolt			
DLBO-8	0.500	460	0.687	2.00	3.50	1.13	1.688	2.500	0.69	.31	.25	.16	# 6	0.75	1.75	0.40
DLBO-10	0.625	640	0.875	2.50	4.00	1.44	2.125	3.000	0.88	.37	.28	.19	# 8	0.94	2.00	0.80
DLBO-12	0.750	940	0.937	2.75	4.50	1.56	2.375	3.500	0.94	.43	.31	.19	# 8	1.00	2.25	1.00
DLBO-16	1.000	1,560	1.187	3.25	6.00	2.00	2.875	4.500	1.19	.56	.38	.22	#10	1.25	3.00	2.00
DLBO-20	1.250	2,340	1.500	4.00	7.50	2.56	3.500	5.500	1.50	.62	.44	.22	#10	1.63	3.75	4.20
DLBO-24	1.500	3,120	1.750	4.75	9.00	2.94	4.125	6.500	1.75	.75	.50	.28	1/4	1.88	4.50	6.70
DLBO-32	2.000	4,700	2.125	6.00	10.00	3.63	5.250	8.250	2.25	1.00	.63	.41	3/8	2.44	5.75	12.75

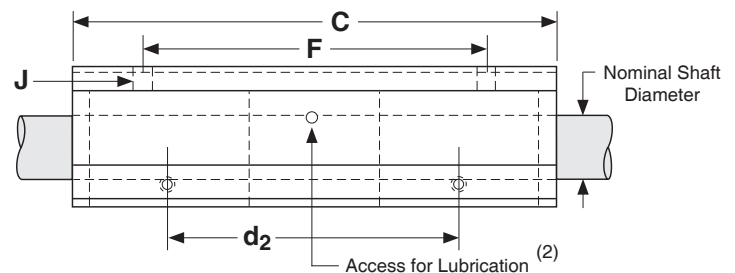
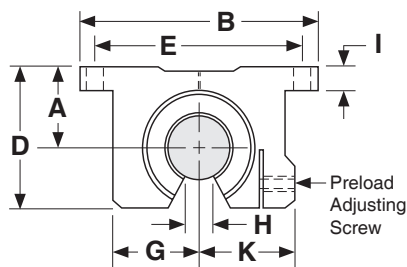

Footnotes:

- (1) Rating based upon 2 million inches of travel with the load forces being applied downward on the linear bearing, while in a horizontal application, and based upon 1060 steel shafting (Rockwell 60C).
- (2) Size 0.500 has oil lubricant fitting. Sizes 0.625 and above have a 1/4-28 UNF straight thread access for lubrication.
- (3) This value is the center to center distance (spacing) of the bearings on a single shaft (d₂).

[More Information via the Web](#)

[More Information via the Web](#)



Specifications: TRCA TWIN RAIL® Carriage Assembly

Bearing Housing Type & Finish	Aluminum 6061-T6 Pillow Block, Natural Finish																
Bearing Seals	Internal Wiper Seals on Both Ends																
Carriage Plate Type & Finish	Machined Aluminum 6061-T6 Plate, Black Anodized																
Bearing Alignment on Plate	+/- 0.001", Pillow Blocks Doweled to Carriage Plate																
Operating Temperature	0° F to + 185° F																
Maximum Speed	9 ft/second																
Matching TWIN RAIL® Assembly	TRSA series (see page 11)																
Diameter Tolerance	<table border="1"> <thead> <tr> <th>Nominal Shaft Diameter (inches)</th> <th>Shaft Diameter Tolerance (inches)</th> </tr> </thead> <tbody> <tr> <td>0.500</td> <td>.4995 / .4990</td> </tr> <tr> <td>0.625</td> <td>.6245 / .6240</td> </tr> <tr> <td>0.750</td> <td>.7495 / .7490</td> </tr> <tr> <td>1.000</td> <td>.9995 / .9990</td> </tr> <tr> <td>1.250</td> <td>1.2495 / 1.2490</td> </tr> <tr> <td>1.500</td> <td>1.4994 / 1.4989</td> </tr> <tr> <td>2.000</td> <td>1.9994 / 1.9987</td> </tr> </tbody> </table>	Nominal Shaft Diameter (inches)	Shaft Diameter Tolerance (inches)	0.500	.4995 / .4990	0.625	.6245 / .6240	0.750	.7495 / .7490	1.000	.9995 / .9990	1.250	1.2495 / 1.2490	1.500	1.4994 / 1.4989	2.000	1.9994 / 1.9987
Nominal Shaft Diameter (inches)	Shaft Diameter Tolerance (inches)																
0.500	.4995 / .4990																
0.625	.6245 / .6240																
0.750	.7495 / .7490																
1.000	.9995 / .9990																
1.250	1.2495 / 1.2490																
1.500	1.4994 / 1.4989																
2.000	1.9994 / 1.9987																

Model Number	Nominal Shaft Diameter (inches)	Dynamic Load Capacity (lbs)	Dimensions (inches)								
			B +/- .005	D	E	F	G	H	K	d _r	d ₁
TRCA8	0.500	920	5.50	0.75	0.68	1.12	2.00	.25	0.375	1.062	3.00
TRCA10	0.625	1,280	6.75	0.93	0.87	1.43	2.50	.25	0.375	1.250	3.75
TRCA12	0.750	1,880	7.75	1.00	0.93	1.56	2.75	.25	0.500	1.437	4.50
TRCA16	1.000	3,120	9.00	1.25	1.18	2.00	3.25	.25	0.500	1.687	5.25
TRCA20	1.250	4,680	10.50	1.62	1.50	2.56	4.00	.25	0.750	2.250	6.00
TRCA24	1.500	6,240	12.00	1.87	1.75	2.93	4.75	.31	1.000	2.750	6.62
TRCA32	2.000	9,400	14.00	2.43	2.25	3.62	6.00	.37	1.250	3.375	7.25

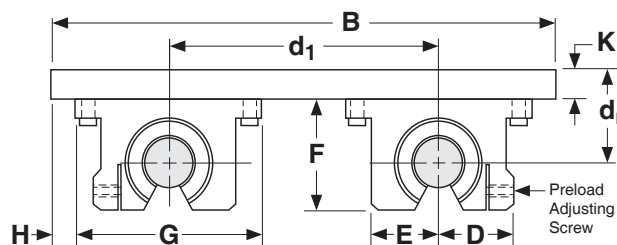

Dimensions & Specifications: TRCA-P Pre-Drilled Mounting Holes

Model Number	Carriage Length (inches)	L (inches)	Threaded Insert Size
TRCA8-6-P	6.00	5.00	#10-32
TRCA8-12-P	12.00	5.00	#10-32
TRCA8-18-P	18.00	5.00	#10-32
TRCA10-6-P	6.00	5.00	#10-32
TRCA10-12-P	12.00	5.00	#10-32
TRCA10-18-P	18.00	5.50	#10-32
TRCA12-6-P	6.00	5.00	1/4-28
TRCA12-12-P	12.00	5.00	1/4-28
TRCA12-18-P	18.00	5.50	1/4-28
TRCA16-6-P	6.00	5.00	5/16-24
TRCA16-12-P	12.00	5.00	5/16-24
TRCA16-18-P	18.00	5.00 </td <td>5/16-24</td>	5/16-24
TRCA16-24-P	24.00	5.00	5/16-24
TRCA20-8-P	8.00	7.00	3/8-24
TRCA20-12-P	12.00	5.00	3/8-24
TRCA20-18-P	18.00	5.00	3/8-24
TRCA20-24-P	24.00	5.00	3/8-24
TRCA24-12-P	12.00	5.00	3/8-24
TRCA24-18-P	18.00	5.00	3/8-24
TRCA24-24-P	24.00	5.00	3/8-24
TRCA24-30-P	30.00	5.25	3/8-24
TRCA32-18-P	18.00	5.00	1/2-20
TRCA32-24-P	24.00	5.00	1/2-20
TRCA32-30-P	30.00	5.25	1/2-20

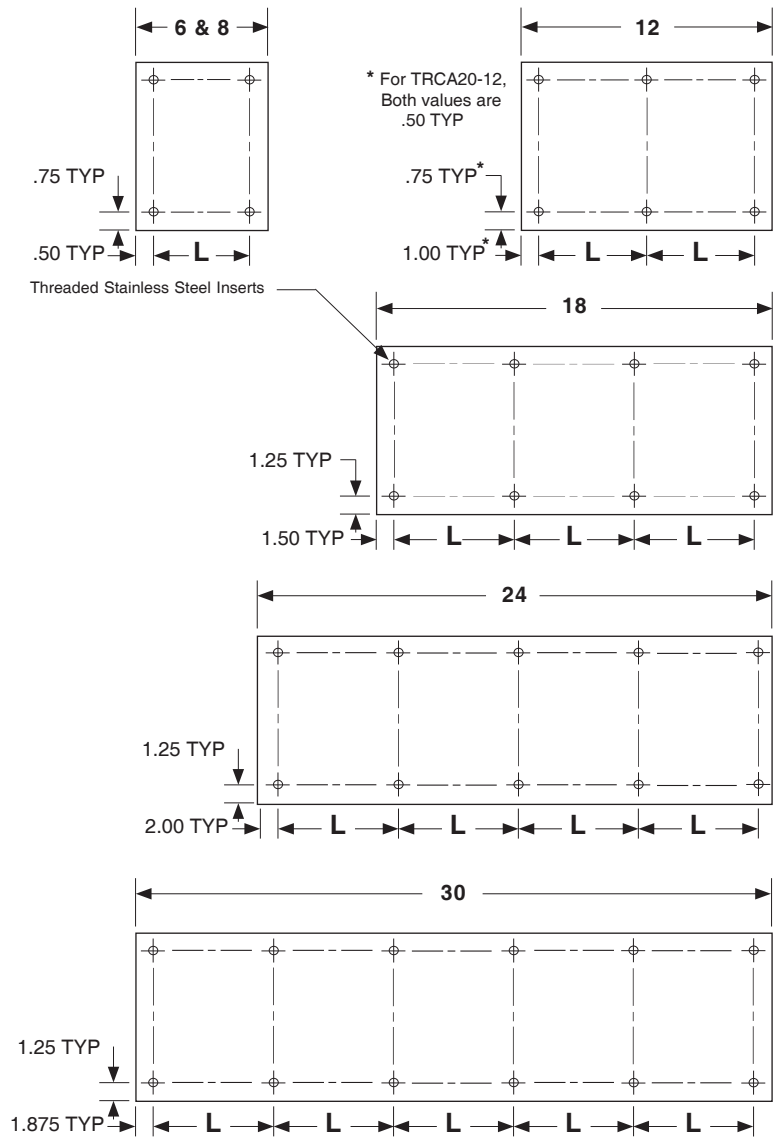

[More Information via the Web](#)

[More Information via the Web](#)



Dimensions & Specifications: **LBCM** Linear Bearing Closed Metric (Asian Style)

Model Number		Nominal Shaft Diameter (mm)	Dynamic Load Capacity N (Kgf)	Housing Bore D (mm)	Dimensions (mm)			No. of Ball Tracks	Bearing Weight (kg)
Without Seals	With Seals				A	B	C		
LBCM-16	LBCM-16-S	16	1225 (119,9)	28	37	26,5	1,60	5	0,034
LBCM-20	LBCM-20-S	20	2303 (239,8)	32	42	30,5	1,60	6	0,058
LBCM-25	LBCM-25-S	25	4312 (459,6)	40	59	41,0	1,85	6	0,120
LBCM-30	LBCM-30-S	30	4802 (569,6)	45	64	44,5	1,85	6	0,148
LBCM-40	LBCM-40-S	40	9310 (949,3)	60	80	60,5	2,10	6	0,314

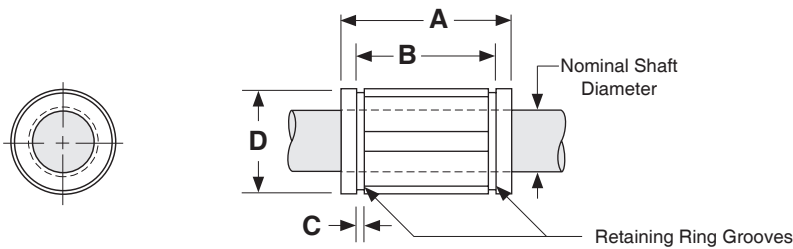

Dimensions & Specifications: **LBOM** Linear Bearing Open Metric (Asian Style)

Model Number		Nominal Shaft Diameter (mm)	Dynamic Load Capacity N (Kgf)	Housing Bore D (mm)	Dimensions (mm)				Angle α	No. of Ball Tracks	Bearing Weight (kg)
Without Seals	With Seals				A	B	C	E min.			
LBOM-16	LBOM-16-S	16	1372 (139,9)	28	37	26,5	1,60	11,0	60°	4	0,026
LBOM-20	LBOM-20-S	20	2332 (237,8)	32	42	30,5	1,60	11,0	60°	5	0,048
LBOM-25	LBOM-25-S	25	4351 (443,7)	40	59	41,0	1,85	12,5	60°	5	0,100
LBOM-30	LBOM-30-S	30	4851 (494,7)	45	64	44,5	1,85	15,0	60°	5	0,122
LBOM-40	LBOM-40-S	40	9408 (959,3)	60	80	60,5	2,15	20,0	60°	5	0,260

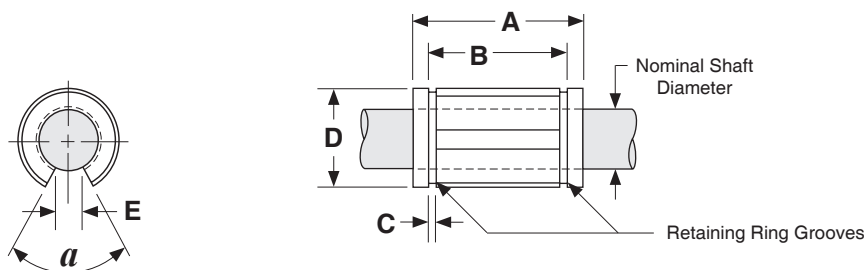

(1) Rating based upon 50 km of travel with the load forces being applied downward on the linear bearing, while in a horizontal application, and based upon 1060 steel shafting (Rockwell 60C).

(2) This specification is based upon the bearing being on the shaft.



Dimensions & Specifications: **LBCME** Linear Bearing Closed Metric (European Style)

Model Number		Nominal Shaft Diameter (mm)	Dynamic Load Capacity N (Kgf)	Housing Bore D (mm)	Dimensions (mm)			No. of Ball Tracks	Bearing Weight (kg)
Without Seals	With Seals				A	B	C		
LBCME-16	LBCME-16-S	16	1176 (119,9)	26	36	24,6	1,30	5	0,026
LBCME-20	LBCME-20-S	20	2352 (239,8)	32	45	31,2	1,60	6	0,060
LBCME-25	LBCME-25-S	25	4508 (459,6)	40	58	43,7	1,85	6	0,120
LBCME-30	LBCME-30-S	30	5586 (569,6)	47	68	51,7	1,85	6	0,184
LBCME-40	LBCME-40-S	40	9310 (949,3)	62	80	60,3	2,15	6	0,342
LBCME-50	LBCME-50-S	50	13720 (1399,0)	75	100	77,3	2,65	6	0,586

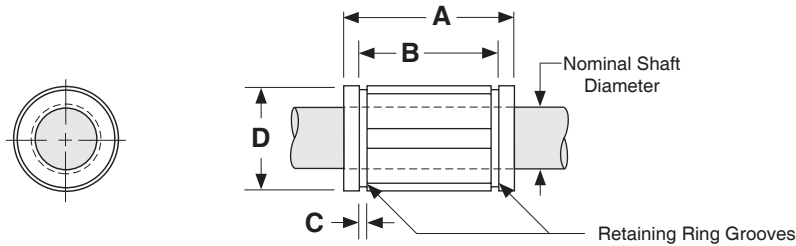

Dimensions & Specifications: **LBOME** Linear Bearing Open Metric (European Style)

Model Number		Nominal Shaft Diameter (mm)	Dynamic Load Capacity N (Kgf)	Housing Bore D (mm)	Dimensions (mm)				Angle α	No. of Ball Tracks	Bearing Weight (kg)
Without Seals	With Seals				A	B	C	E min.			
LBOME-16	LBOME-16-S	16	1332 (135,8)	26	36	24,6	1,30	9,0	68°	4	0,020
LBOME-20	LBOME-20-S	20	2371 (241,8)	32	45	31,2	1,60	9,0	55°	5	0,050
LBOME-25	LBOME-25-S	25	4557 (464,7)	40	58	43,7	1,85	11,5	57°	5	0,100
LBOME-30	LBOME-30-S	30	5644 (575,5)	47	68	51,7	1,85	14,0	57°	5	0,154
LBOME-40	LBOME-40-S	40	9398 (958,3)	62	80	60,3	2,15	19,5	56°	5	0,286
LBOME-50	LBOME-50-S	50	13857 (1413,0)	75	100	77,3	2,65	22,5	54°	5	0,486

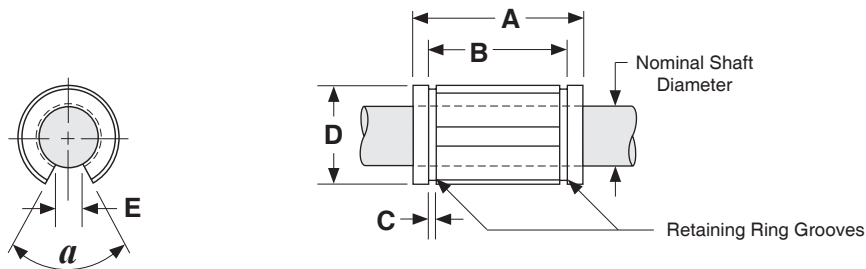

(1) Rating based upon 50 km of travel with the load forces being applied downward on the linear bearing, while in a horizontal application, and based upon 1060 steel shafting (Rockwell 60C).

(2) This specification is based upon the bearing being on the shaft.

SLBCM Series

Single Self-Aligning Closed



SLBCM-A Series

Single Self-Aligning Closed Adjustable



[More Information via the Web](#)

SLBOM Series

Single Self-Aligning Open



DLBCM Series

Double Self-Aligning Closed



[More Information via the Web](#)

SLBCME Series

Single Self-Aligning Closed



SLBCME-A Series

Single Self-Aligning Closed Adjustable



SLBOME Series

Single Self-Aligning Open



SLBOME-A Series

Single Self-Aligning Open Adjustable



DLBCME Series

Double Self-Aligning Closed



DLBCME-A Series

Single Self-Aligning Closed Adjustable



DLBOME Series

Double Self-Aligning Open



DLBOME-A Series

Double Self-Aligning Open Adjustable



MR series

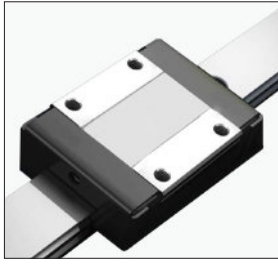

- * Miniature Rail linear guide
- * Standard and Wide wide bearing blocks
- * Standard and Long length bearing blocks
- * Stainless steel bearing, rail, and balls
- * 2 rows of re-circulating balls
- * 2, 3, 5, 7, 9, 12, 15 mm rail sizes
- * Normal, High and Precision accuracy grades
- * Zero, Standard and Medium preload options
- * Dust proof design

[More Information via the Web](#)

ARC series

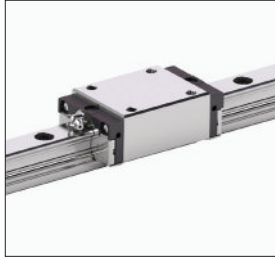

- * Standard profile height bearing blocks
- * Standard and Flanged wide bearing blocks
- * Short, Standard, and Long length bearing blocks
- * 15, 20, 25, 30, 35, 45 mm rail sizes
- * Equal loading in all directions
- * Normal, High, and Precision accuracy grades
- * Light, Medium, and Heavy preload options
- * Low noise Ball Chain *optional*
- * Self lube reservoir *optional*

HRC series



- * Heavy / High profile height bearing blocks
- * Standard and Flanged wide bearing blocks
- * Standard, and Long length bearing blocks
- * 15, 20, 25, 30, 35, 45 mm rail sizes
- * Equal loading in all directions
- * Normal, High, and Precision accuracy grades
- * Light, Medium, and Heavy preload options
- * Low noise Ball Chain *optional*
- * Self lube reservoir *optional*

WRC series



- * Wide Rail linear guides
- * Standard and Flanged wide bearing blocks
- * Standard length bearing blocks
- * 4 rows of re-circulating balls
- * Equal loading in all directions
- * Normal, High, and Precision accuracy grades
- * Light, Medium, and Heavy preload options
- * Low noise Ball Chain *optional*
- * Self lube reservoir *optional*

ARR series



- * Standard profile height roller bearing blocks
- * Standard and Flanged wide roller bearing blocks
- * Standard, and Long length roller bearing blocks
- * 4 rows of re-circulating rollers
- * Equal loading in all directions
- * High and Precision accuracy grades
- * Light, Medium, and Heavy preload options
- * Low noise Ball Chain *optional*

HRR series



- * High profile height roller bearing blocks
- * Standard and Flanged wide roller bearing blocks
- * Standard, and Long length roller bearing blocks
- * 4 rows of re-circulating rollers
- * Equal loading in all directions
- * High and Precision accuracy grades
- * Light, Medium, and Heavy preload options
- * Low noise Ball Chain *optional*

[More Information via the Web](#)

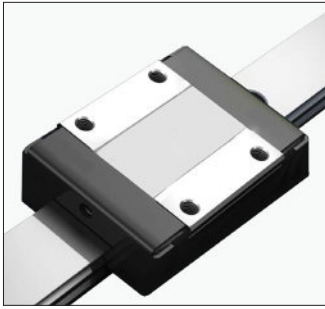

- * Miniature Rail
- * 2 rows of re-circulating balls
- * Equal loading in all directions
- * Dust proof design

Load Capacities: **MR** Miniature Linear Guides

Model Number	Dynamic Load Capacity C_{50} (kN @ 50 km)	Static Load Capacity C_0 (kN)	Static Moment Loads		
			M_r (Nm)	M_p (Nm)	M_y (Nm)
MRU 3 MN	.24	.31	.6	.4	.4
MR 3 WN	.35	.53	1.6	.9	.9
MRU 3 ML	.37	.58	.9	1.1	1.1
MR 2 WL	.39	.62	1.6	1.2	1.2
MR 5 MN	.42	.55	1.7	1.0	1.0
MR 3 WL	.47	.80	2.5	1.9	1.9
MR 5 ML	.59	.90	2.4	2.1	2.1
MR 5 WN	.60	.90	4.6	2.2	2.2
MR 5 WL	.77	1.31	6.8	4.1	4.1
MR 7 MN	1.12	1.44	5.2	3.3	3.3
MR 7 WN	1.49	2.09	15.0	7.3	7.3
MR 7 ML	1.65	2.44	9.0	7.7	7.7
MR 7 WL	1.97	3.14	22.6	14.9	14.9
MR 9 MN	1.98	2.49	11.7	6.4	6.4
MR 9 WN	2.56	3.60	33.2	13.7	13.7
MR 9 ML	2.69	3.88	18.2	12.4	12.4
MR 12 MN	2.91	3.46	21.5	12.9	12.9
MR 9 WL	3.21	4.99	45.9	26.7	26.7
MR 12 WN	3.86	5.20	63.7	26.3	26.3
MR 12 ML	4.08	5.63	34.9	30.2	30.2
MR 15 MN	4.80	5.59	43.6	27.0	27.0
MR 12 WL	5.13	7.80	95.6	56.4	56.4
MR 15 WN	6.38	8.38	171.1	45.7	45.7
MR 15 ML	6.74	9.08	70.0	63.3	63.3
MR 15 WL	8.47	12.58	257.6	93.1	93.1

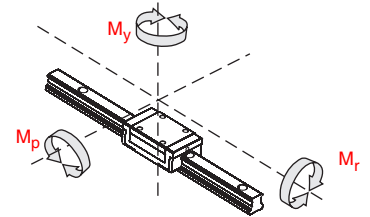

Dimensions & Specifications: MR Linear Guides with End and Bottom Seals

Model Number	Outline (mm)			Block Dimensions (mm)								Rail Dimensions (mm)					Weight	
	Height H	Width W	Length L	B	C	M x T	K	G	N	J	E	P	X	A	F	Q x R x S	Block (g)	Rail (g/m)
MRU3MNSS MRU3MLSS	4	8	11.7 16.0	-	3.5 5.5	M1.6 x 1.1 M2 x 1.1	3.1	6.7 11.0	0.3	0.7	1.5	3	2.5	2.6	10	M1.6	0.9 1.2	53
MR5MNSU/ZU MR5MLSU/ZU	6	12	16.0 19.6	8	- 7	M2 x 1.5 M2.6 x 2	4.6	10.0 13.5	0.7	1.3	2.0	5	3.5	3.5	15	2.4 x 3.5 x 1	3.5 4	116
MR7MNSU/ZU MR7MLSU/ZU	8	17	23.7 31.2	12	8 13	M2 x 2.5	6.7	14.3 21.8	1.1	1.6	2.8	7	5.0	4.7	15	2.4 x 4.2 x 2.3	8 14	215
MR9MNSU/ZU MR9MLSU/ZU	10	20	30.6 40.9	15	10 16	M3 x 3.0	8.0	20.5 30.8	1.3	2.2	3.3	9	5.5	5.5	20	3.5 x 6 x 3.5	18 28	301
MR12MNSU/ZU MR12MLSU/ZU	13	27	35.4 47.6	20	15 20	M3 x 3.5	10.2	22.0 34.0	1.3	3.2	4.3	12	7.5	7.5	25	3.5 x 6 x 4.5	34 51	602
MR15MNSU/ZU MR15MLSU/ZU	16	32	43.0 60.0	25	20 25	M3 x 5.5	12.3	27.0 44.0	1.8	3.3	4.3	15	8.5	9.5	40	3.5 x 6 x 4.5	61 90	930

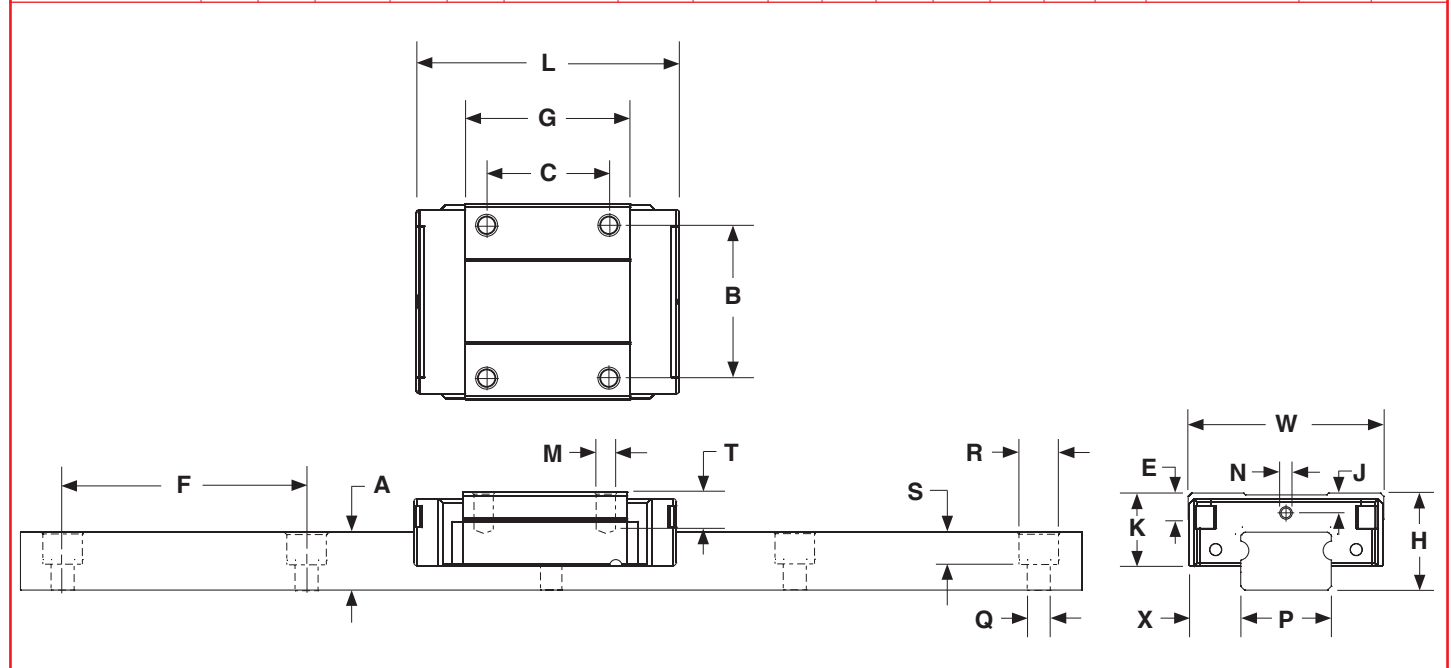

[More Information via the Web](#)

Dimensions & Specifications: MR Linear Guides with End and Bottom Seals plus Reinforcement Plate

Model Number	Outline (mm)			Block Dimensions (mm)								Rail Dimensions (mm)					Weight	
	Height H	Width W	Length L	B	C	M x T	K	G	N	J	E	P	X	A	F	Q x R x S	Block (g)	Rail (g/m)
MR 5 MN SUE/ZUE MR 5 ML SUE/ZUE	6	12	16.6 20.2	8 -	- 7	M2 x 1.5 M2.6 x 2	5.0	10.0 13.5	0.7	1.3	2.0	5	3.5	3.5	15	2.4 x 3.5 x 1	3.5 4	116
MR 9 MN SUE/ZUE MR 9 ML SUE/ZUE	10	20	31.6 41.9	15	10 16	M3 x 3.0	8.5	20.5 30.8	1.3	2.2	3.3	9	5.5	5.5	20	3.5 x 6 x 3.5	18 28	301
MR 12 MN SUE/ZUE MR 12 ML SUE/ZUE	13	27	36.8 49.0	20	15 20	M3 x 3.5	10.9	22.0 34.0	1.3	3.2	4.3	12	7.5	7.5	25	3.5 x 6 x 4.5	34 51	602
MR 15 MN SUE/ZUE MR 15 ML SUE/ZUE	16	32	44.6 61.6	25	20 25	M3 x 5.5	13.1	27.0 44.0	1.8	3.3	4.3	15	8.5	9.5	40	3.5 x 6 x 4.5	61 90	930

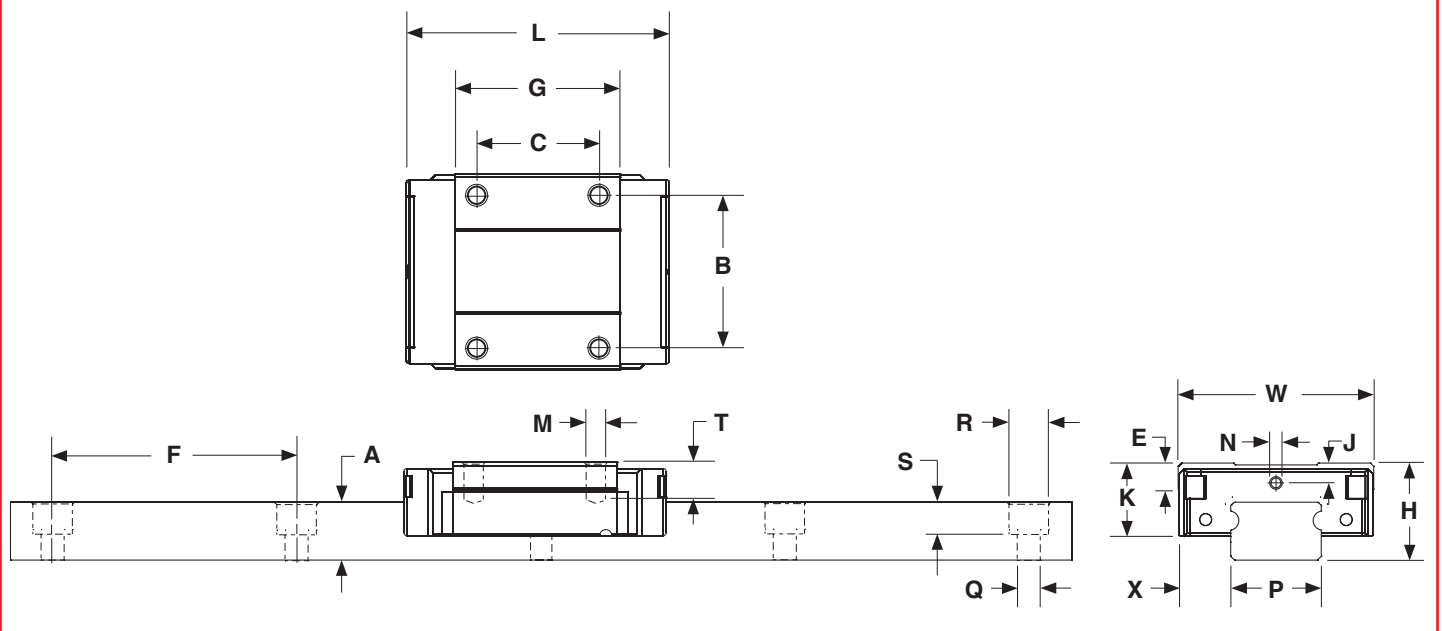

[More Information via the Web](#)

Dimensions & Specifications: MR Linear Guides with End and Bottom Seals

Model Number	Outline (mm)			Block Dimensions (mm)								Rail Dimensions (mm)						Weight	
	Height H	Width W	Length L	B	C	M x T	K	G	N	J	E	P	X	A	F	Q x R x S	Block (g)	Rail (g/m)	
MR2 WL SU/ZU	4	10	17.0	-	6.5	M2 x 1.3	3.1	11.9	-	-	1.3	4	3	3	10	1.8 x 2.8 x 1	3.0	69	
MR3 WN SU/ZU MR3 WL SU/ZU	4.5	12	15.0 20.1	-	4.5 8	M2 x 1.4	3.6	10.0 15.1	0.3	0.8	1.8	6	3	2.7	18	2.4 x 4 x 1.5	3.4 3.4	105	
MR5 WN SU/ZU MR5 WL SU/ZU	6.5	17	21.1 27.2	13	6.5 11	M2.5 x 1.5	5.1	15.1 21.2	0.9	1.2	2.3	10	3.5	4	20	3 x 5.5 x 1.6	6 8	280	
MR7 WN SU/ZU MR7 WL SU/ZU	9	25	31.6 40.5	19	10 19	M3 x 3.0	7.2	21.2 30.1	1.1	1.9	3.2	14	5.5	5.2	30	3.5 x 6 x 3.5	19 27	516	
MR9 WN SU/ZU MR9 WL SU/ZU	12	30	39.1 50.7	21 23	12 24	M3 x 3.0	8.8	27.9 39.5	1.3	2.6	4.0	18	6	7.3	30	3.5 x 6 x 4.5	37 51	940	
MR12 WN SU/ZU MR12 WL SU/ZU	14	40	44.4 59.4	28	15 28	M3 x 3.5	10.4	31.0 46.0	1.3	3.1	4.5	24	8	8.5	40	4.5 x 8 x 4.5	65 93	1472	
MR15 WN SU/ZU MR15 WL SU/ZU	16	60	55.3 74.4	45	20 35	M4 x 4.5	12.3	38.5 57.6	1.8	3.3	4.5	42	9	9.5	40	4.5 x 8 x 4.5	137 200	2818	

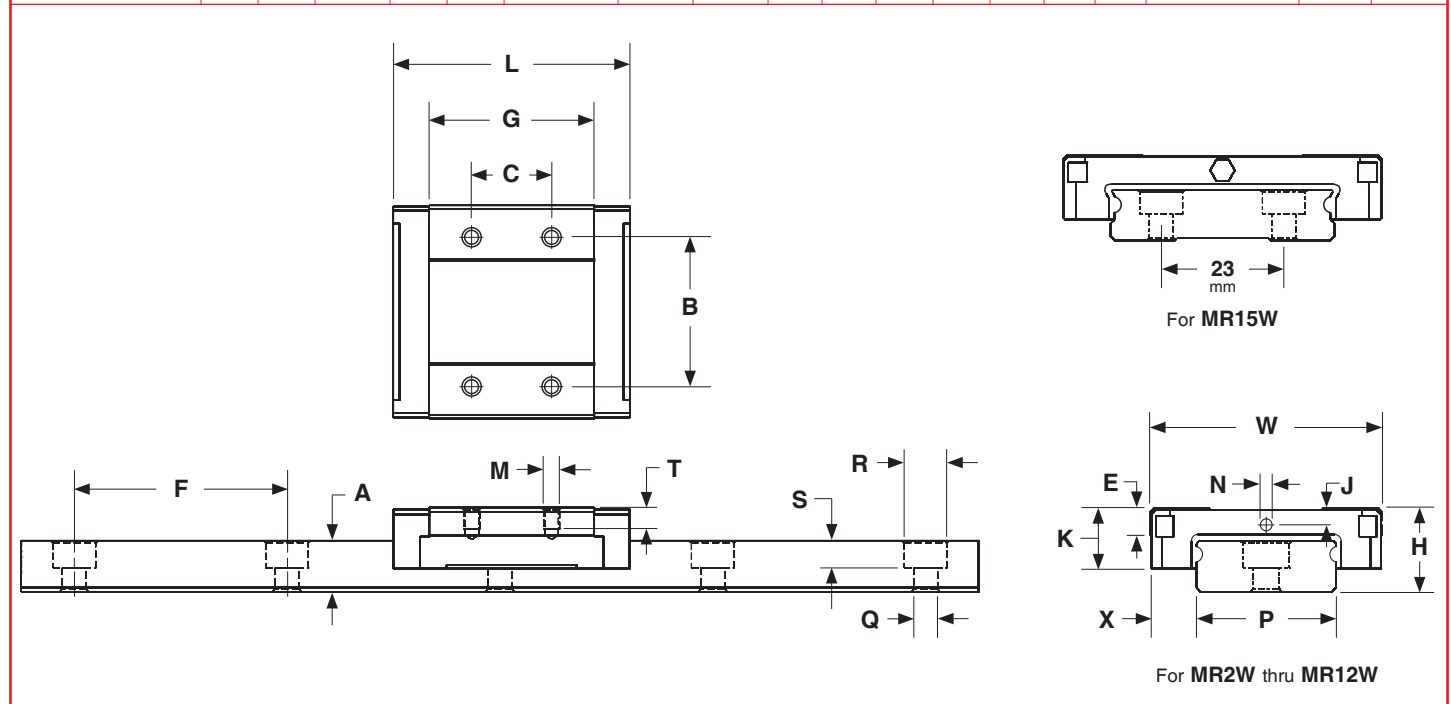

[More Information via the Web](#)

Dimensions & Specifications: MR Linear Guides with End and Bottom Seals plus Reinforcement Plate

Model Number	Outline (mm)			Block Dimensions (mm)								Rail Dimensions (mm)					Weight	
	Height H	Width W	Length L	B	C	M x T	K	G	N	J	E	P	X	A	F	Q x R x S	Block (g)	Rail (g/m)
MR 2 WL SUE/ZUE	4	10	17.5	-	6.5	M2 x 1.3	3.4	11.9	-	-	1.3	4	3	3	10	1.8 x 2.8 x 1	3.0	69
MR 7 WN SUE/ZUE MR 7 WL SUE/ZUE	9	25	32.5 41.5	19	10 19	M3 x 3.0	7.6	21.2 30.1	1.1	1.9	3.2	14	5.5	5.2	30	3.5 x 6 x 3.5	19 27	516
MR 9 WN SUE/ZUE MR 9 WL SUE/ZUE	12	30	40.2 51.8	21 23	12 24	M3 x 3.0	9.4	27.9 39.5	1.3	2.6	4.0	18	6	7.3	30	3.5 x 6 x 4.5	37 51	940
MR 12 WN SUE/ZUE MR 12 WL SUE/ZUE	14	40	45.8 60.8	28	15 28	M3 x 3.5	11.2	31.0 46.0	1.3	3.1	4.5	24	8	8.5	40	4.5 x 8 x 4.5	68 96	1472
MR 15 WN SUE/ZUE MR 15 WL SUE/ZUE	16	60	56.9 76.0	45	20 35	M4 x 4.5	13.1	38.5 57.6	1.8	3.3	4.5	42	9	9.5	40	4.5 x 8 x 4.5	140 203	2818

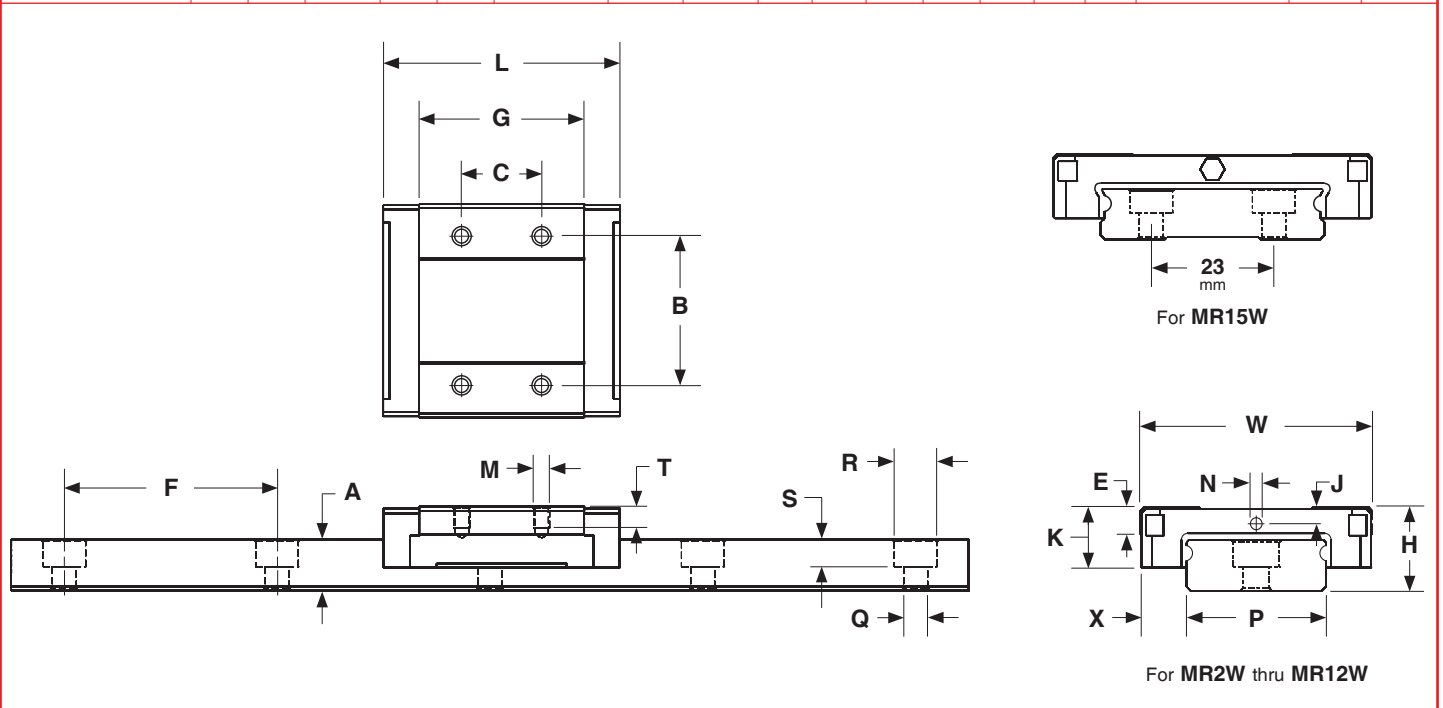

[More Information via the Web](#)

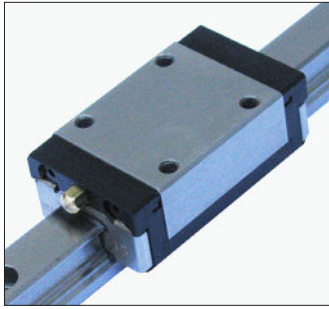

- * Standard Load Rail
- * 4 rows of re-circulating balls
- * Equal loading in all directions
- * Dust proof design
- * Alloy steel bearing, rail, and balls
- * Self lube reservoir *optional*

[More Information via the Web](#)

Load Capacities: **ARC** Linear Guides

Model Number	Dynamic Load Capacity C ₅₀ (kN @ 50 km)	Static Load Capacity C ₀ (kN)	Static Moment Loads		
			M _r (Nm)	M _p (Nm)	M _y (Nm)
ARC 15 MS ARC 15 FS	9.7	12.1	100	50	50
ARC 15 MN ARC 15 FN	12.5	17.5	140	105	105
ARC 20 MS ARC 20 FS	15.7	19.3	205	100	100
ARC 15 ML	16.9	26.9	215	235	235
ARC 20 MN ARC 20 FN	21.5	30.0	325	230	230
ARC 25 MS ARC 25 FS	22.9	27.3	350	160	160
ARC 20 ML	25.7	38.5	415	390	390
ARC 25 MN ARC 25 FN	31.2	42.5	540	385	385
ARC 30 MS ARC 30 FS	29.3	33.1	520	230	230
ARC 30 MN ARC 30 FN	41.3	53.7	845	565	565
ARC 30 ML	49.9	70.2	1105	950	950
ARC 35 MN ARC 35 FN	57.8	82.9	1700	1080	1080
ARC 35 ML	68.9	106.5	2185	1755	1755
ARC 45 MN	89.8	122.1	3200	1910	1910
ARC 45 ML	112.8	169.1	4430	3460	3460

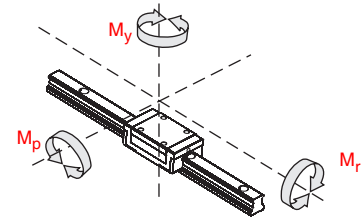

[More Information via the Web](#)

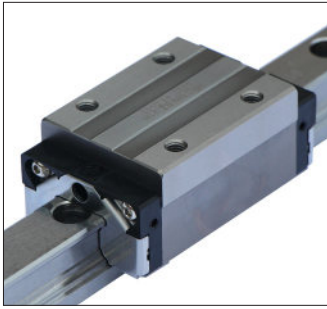

- * Heavy Load Rail
- * 4 rows of re-circulating balls
- * Equal loading in all directions
- * Dust proof design
- * Alloy steel bearing, rail, and balls
- * Self lube reservoir *optional*

Load Capacities: **HRC** Linear Guides

Model Number	Dynamic Load Capacity C_{50} (kN @ 50 km)	Static Load Capacity C_0 (kN)	Static Moment Loads		
			M_r (Nm)	M_p (Nm)	M_y (Nm)
HRC 15 MN HRC 15 FN	12.5	17.5	140	105	105
HRC 20 MN HRC 20 FN	21.5	30.0	325	230	230
HRC 20 ML HRC 20 FL	25.7	38.5	415	390	390
HRC 25 MN HRC 25 FN	31.2	42.5	540	385	385
HRC 25 ML HRC 25 FL	38.7	57.7	735	710	710
HRC 30 MN HRC 30 FN	41.3	53.7	845	565	565
HRC 30 ML HRC 30 FL	49.9	70.2	1105	950	950
HRC 35 MN HRC 35 FN	57.8	82.9	1700	1080	1080
HRC 35 ML HRC 35 FL	68.9	106.5	2185	1755	1755
HRC 45 MN HRC 45 FN	89.8	122.1	3200	1910	1910
HRC 45 ML HRC 45 FL	112.8	169.1	4430	3460	3460

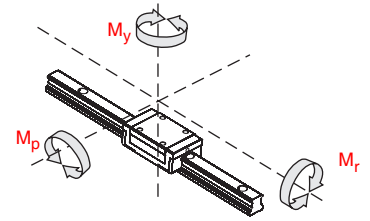

Dimensions & Specifications

Model Number	Outline (mm)			Block Dimensions (mm)								Rail Dimensions (mm)					Weight	
	Height H	Width W	Length L	B	C	M x T	K	G	N	J	E	P	X	A	F	Q x R x S	Block (kg)	Rail (kg/m)
ARC 15 MS			41.2		-			26.0									0.11	
ARC 15 MN	24	34	55.5	26	26	M4 x 7	20.7	40.3	M3 x 6.5	4.5	3.5	15	9.5	15	60	4.5 x 7.5 x 5.3	0.16	1.29
ARC 15 ML			76.2		34			61.0									0.24	
ARC 20 MS			49.2		-			32.2									0.17	
ARC 20 MN	28	42	69.0	32	32	M5 x 7	23.0	52.0	M3 x 7.5	4	10	20	11	20	60	6 x 9.5 x 8.5	0.27	2.28
ARC 20 ML			87.2		45			70.2									0.33	
ARC 25 MS			57.4		-			38.4									0.30	
ARC 25 MN	33	48	81.2	35	35	M6 x 9	27.0	62.2	M6 x 7.5	5	12	23	12.5	23	60	7 x 11 x 9	0.42	3.02
ARC 30 MS			68.0		-			44.0									0.56	
ARC 30 MN	42	60	95.5	40	40	M8 x 10	35.2	71.5	M6 x 8.5	7.5	12	28	16	27	80	9 x 14 x 12	0.80	4.38
ARC 30 ML			118.0		60			94.0									1.14	
ARC 35 MN			111.2		50			86.2									1.12	
ARC 35 ML	48	70	136.6	50	72	M8 x 13	40.4	111.6	M6 x 10	8	12	34	18	32	80	9 x 14 x 12	1.54	6.79
ARC 45 MN			135.5		60			102.5									2.12	
ARC 45 ML	60	86	171.5	60	80	M10 x 17	50.7	138.5	PT1/8 x 12.5	11.1	14	45	20.5	39	105	14 x 20 x 17	3.16	10.53

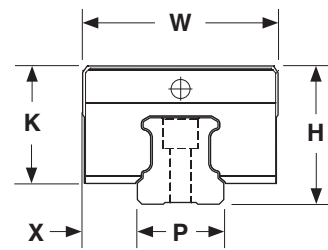
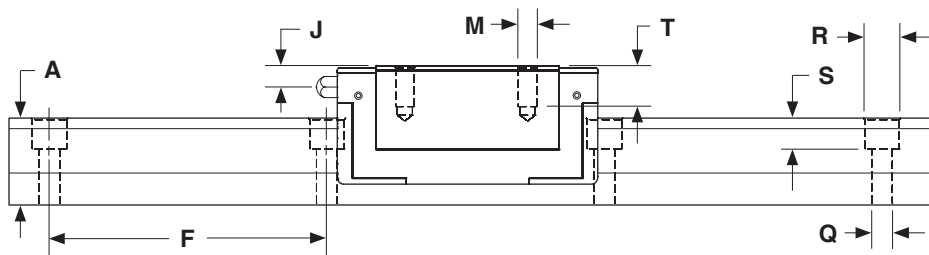
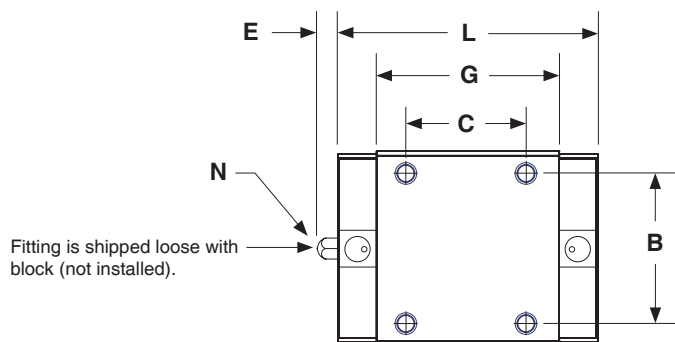

Rail Size	(mm)			
	D x Y	P	A	F
ARCU 15	M5 x 8	15	15	60
ARCU 20	M6 x 10	20	20	60
ARCU 25	M6 x 12	23	23	60
ARCU 30	M8 x 15	28	27	80
ARCU 35	M8 x 15	34	32	80
ARCU 45	M12 x 19	45	39	105

Rail Tapped from Bottom

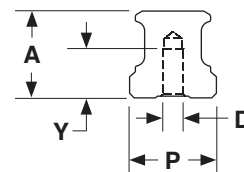
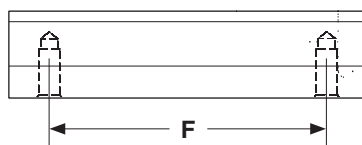

Dimensions & Specifications

Model Number	Outline (mm)			Block Dimensions (mm)									Rail Dimensions (mm)						Weight	
	Height H	Width W	Length L	B	C	M x T	V	K	G	N	J	E	P	X	A	F	Q x R x S	Block (kg)	Rail (kg/m)	
ARC 15 FS ARC 15 FN	24	52	41.2 55.5	41	- 26	M5 x 7	M4	20.7	26.0 40.3	M3 x 6.5	4.5	3.5	15	18.5	15	60	4.5 x 7.5 x 5.3	0.12 0.18	1.29	
ARC 20 FS ARC 20 FN	28	59	49.2 69.0	49	- 32	M6 x 10	M5	23.0	32.2 52.0	M3 x 7.5	4	10	20	19.5	20	60	6 x 9.5 x 8.5	0.21 0.34	2.28	
ARC 25 FS ARC 25 FN	33	73	57.4 81.2	60	- 35	M8 x 12	M6	27.0	38.4 62.2	M6 x 7.5	5	12	23	25	23	60	7 x 11 x 9	0.35 0.53	3.02	
ARC 30 FS ARC 30 FN	42	90	68.0 95.5	72	- 40	M10 x 15	M8	35.2	44.0 71.5	M6 x 8.5	7.5	12	28	31	27	80	9 x 14 x 12	0.75 1.20	4.38	
ARC 35 FN	48	100	111.2	82	50	M10 x 15	M8	40.2	86.2	M6 x 10	8	12	34	33	32	80	9 x 14 x 12	1.58	6.79	

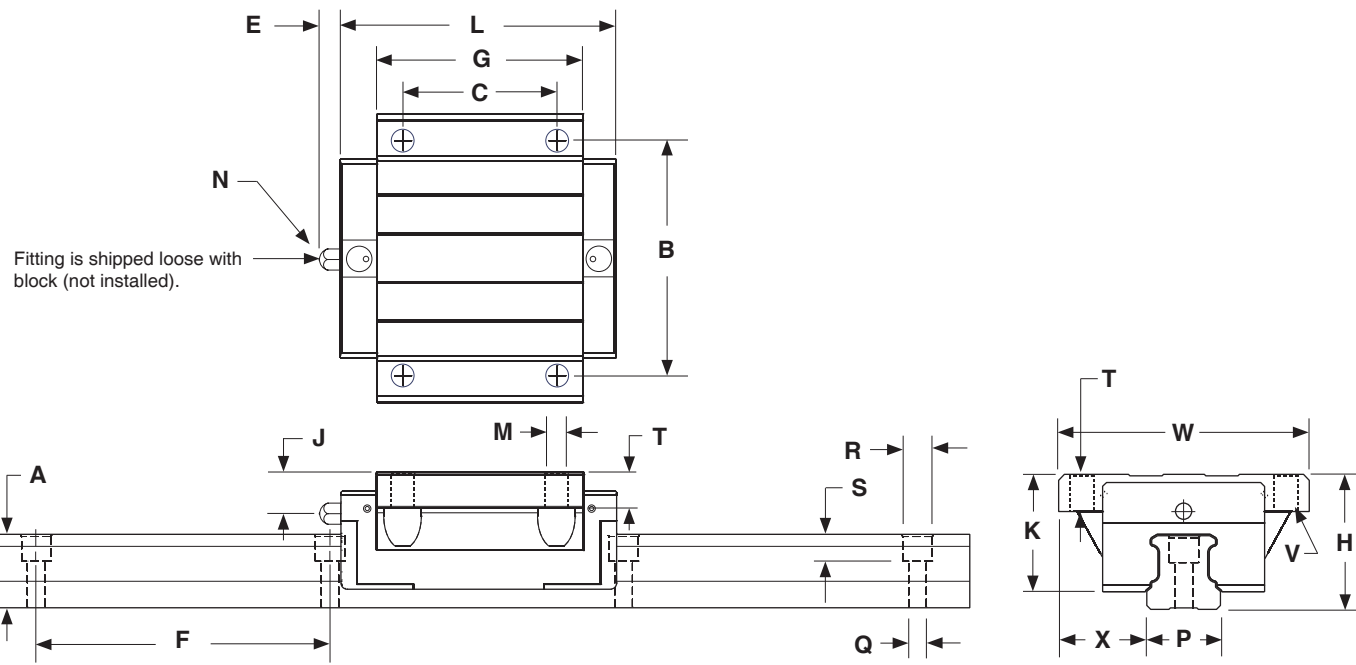

Rail Size	(mm)			
	D x Y	P	A	F
ARCU 15	M5 x 8	15	15	60
ARCU 20	M6 x 10	20	20	60
ARCU 25	M6 x 12	23	23	60
ARCU 30	M8 x 15	28	27	80
ARCU 35	M8 x 15	34	32	80
ARCU 45	M12 x 19	45	39	105

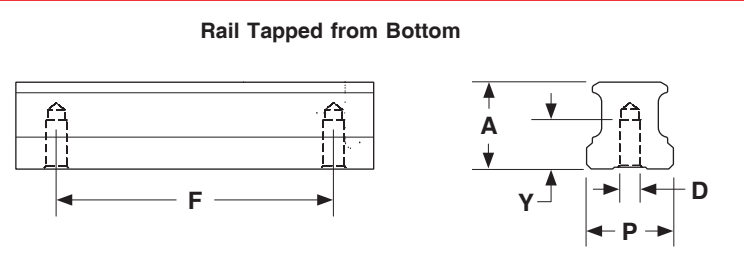

Dimensions & Specifications

Model Number	Outline (mm)			Block Dimensions (mm)								Rail Dimensions (mm)					Weight	
	Height H	Width W	Length L	B	C	M x T	K	G	N	J	E	P	X	A	F	Q x R x S	Block (kg)	Rail (kg/m)
HRC 15 MN HRC 15 ML	28	34	55.5	26	26	M4 x 7	24.7	40.3	M3 x 6.5	8.5	3.5	15	9.5	15	60	4.5 x 7.5 x 5.3	0.18	1.29
HRC 20 MN HRC 20 ML	30	44	69.0 87.2	32	36 50	M5 x 8.5	25.0	52.0 70.2	M3 x 7.5	6	10	20	12	20	60	6 x 9.5 x 8.5	0.32 0.40	2.28
HRC 25 MN HRC 25 ML	40	48	81.2 105.0	35	35 50	M6 x 9	34.0	62.2 86.0	M6 x 7.5	12	12	23	12.5	23	60	7 x 11 x 9	0.58 0.69	3.02
HRC 30 MN HRC 30 ML	45	60	95.5 118.0	40	40 60	M8 x 12	38.4	71.5 94.0	M6 x 8.5	10.5	12	28	16	27	80	9 x 14 x 12	0.90 1.15	4.38
HRC 35 MN HRC 35 ML	55	70	111.2 136.6	50	50 72	M8 x 13	47.4	86.2 111.6	M6 x 10	15	12	34	18	32	80	9 x 14 x 12	1.43 1.95	6.79
HRC 45 MN HRC 45 ML	70	86	135.5 171.5	60	60 80	M10 x 20	60.7	102.5 138.5	PT1/8 x 12.5	21.1	14	45	20.5	39	105	14 x 20 x 17	2.79 4.06	10.53

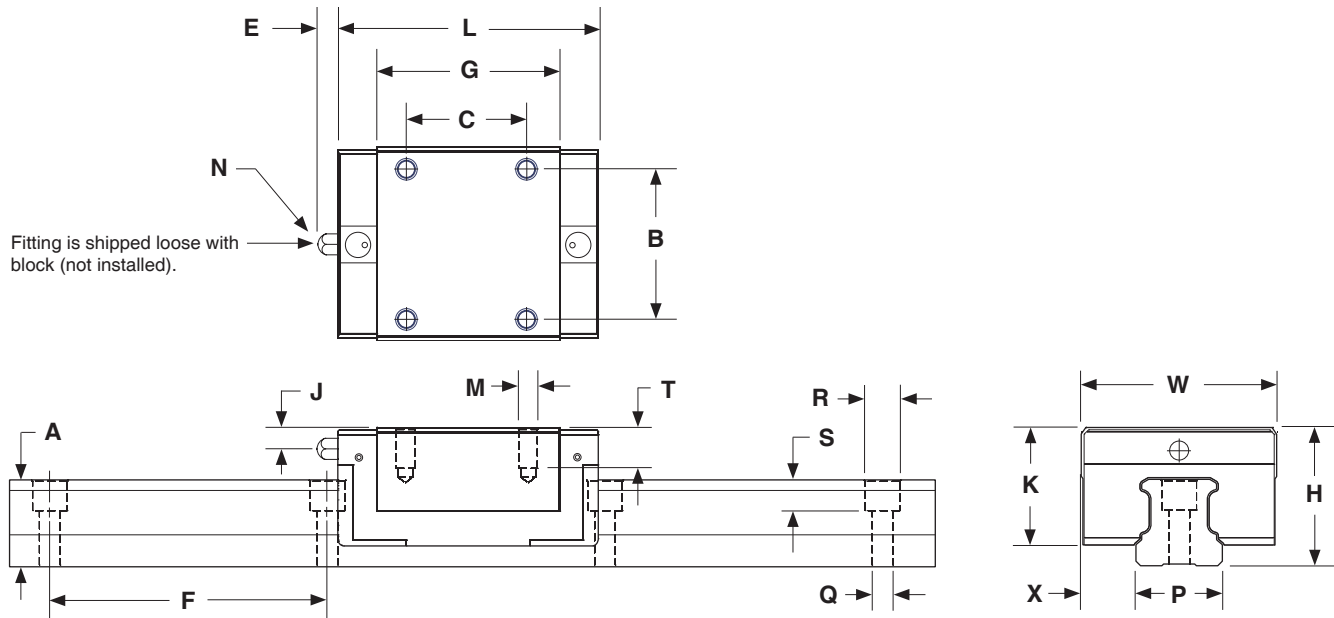

Rail Size	(mm)			
	D x Y	P	A	F
HRCU 15	M5 x 8	15	15	60
HRCU 20	M6 x 10	20	20	60
HRCU 25	M6 x 12	23	23	60
HRCU 30	M8 x 15	28	27	80
HRCU 35	M8 x 15	34	32	80
HRCU 45	M12 x 19	45	39	105

Rail Tapped from Bottom

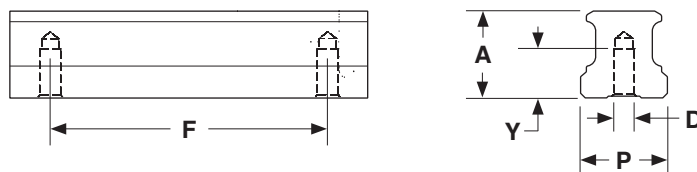

[More Information via the Web](#)

Dimensions & Specifications

Model Number	Outline (mm)			Block Dimensions (mm)									Rail Dimensions (mm)						Weight	
	Height H	Width W	Length L	B	C	M x T	V	K	G	N	J	E	P	X	A	F	Q x R x S	Block (kg)	Rail (kg/m)	
HRC 15 FN HRC 15 FL	24	47	55.5	38	30	M5 x 7	M4	20.7	40.3	M3 x 6.5	4.5	3.5	15	16	15	60	4.5 x 7.5 x 5.3	0.18	1.29	
HRC 20 FN HRC 20 FL	30	63	69.0 87.2	53	40	M6 x 10	M5	25.0	52.0 70.2	M3 x 7.5	6	10	20	21.5	20	60	6 x 9.5 x 8.5	0.40 0.51	2.28	
HRC 25 FN HRC 25 FL	36	70	81.2 105.0	57	45	M8 x 12	M6	30.0	62.2 86.0	M6 x 7.5	8	12	23	23.5	23	60	7 x 11 x 9	0.63 0.87	3.02	
HRC 30 FN HRC 30 FL	42	90	95.5 118.0	72	52	M10 x 15	M8	35.2	71.5 94.0	M6 x 8.5	7.5	12	28	31	27	80	9 x 14 x 12	1.11 1.39	4.38	
HRC 35 FN HRC 35 FL	48	100	111.2 136.6	82	62	M10 x 15	M8	40.4	86.2 111.6	M6 x 10	8	12	34	33	32	80	9 x 14 x 12	1.55 2.00	6.79	
HRC 45 FN HRC 45 FL	60	120	135.5 171.5	100	80	M12 x 18	M10	50.7	102.5 138.5	PT1/8 x 12.5	11.1	14	45	37.5	39	105	14 x 20 x 17	2.75 4.28	10.53	

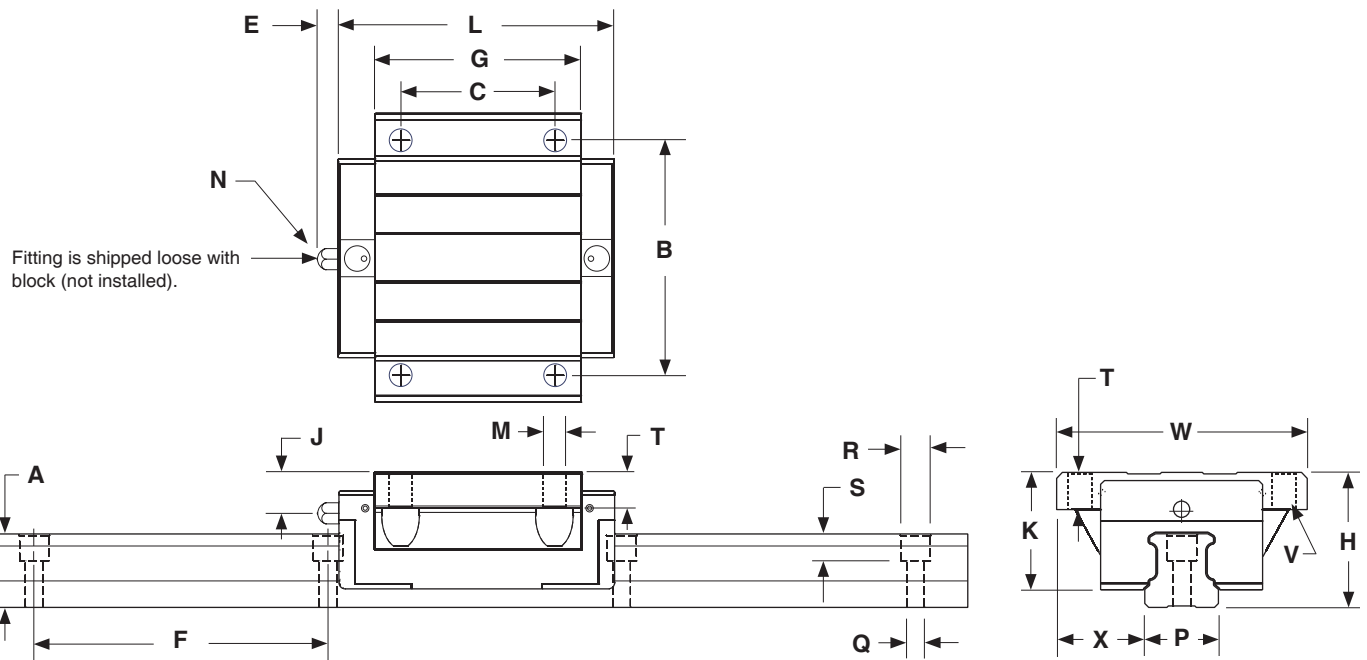

Rail Size	(mm)			
	D x Y	P	A	F
HRCU 15	M5 x 8	15	15	60
HRCU 20	M6 x 10	20	20	60
HRCU 25	M6 x 12	23	23	60
HRCU 30	M8 x 15	28	27	80
HRCU 35	M8 x 15	34	32	80
HRCU 45	M12 x 19	45	39	105

Rail Tapped from Bottom

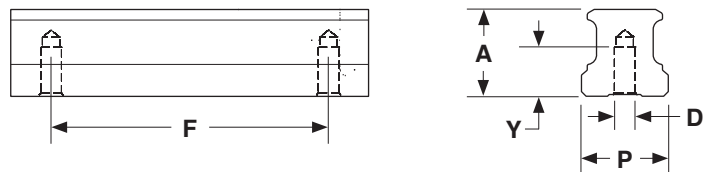

[More Information via the Web](#)

Dimensions & Specifications

Model Number	Outline (mm)			Block Dimensions (mm)									Rail Dimensions (mm)						Weight	
	Height H	Width W	Length L	B	C	M x T	K	G	Z	N	J	E	P	V	X	A	F	Q x R x S	Block (kg)	Rail (kg/m)
WRC 21/15 MN	21	54	57.5	31	19	M5 x 5	18.3	40.3	6	M3 x 6.5	3.3	3.5	37	22	8.5	14.4	50	4.5 x 7.5 x 5.3	0.16	3.60
WRC 27/20 MN	27	62	70	46	32	M6 x 6	23.5	52	9	M3 x 7.5	4.5	3.5	42	24	10	18.5	60	4.5 x 7.5 x 5.3	0.32	5.26

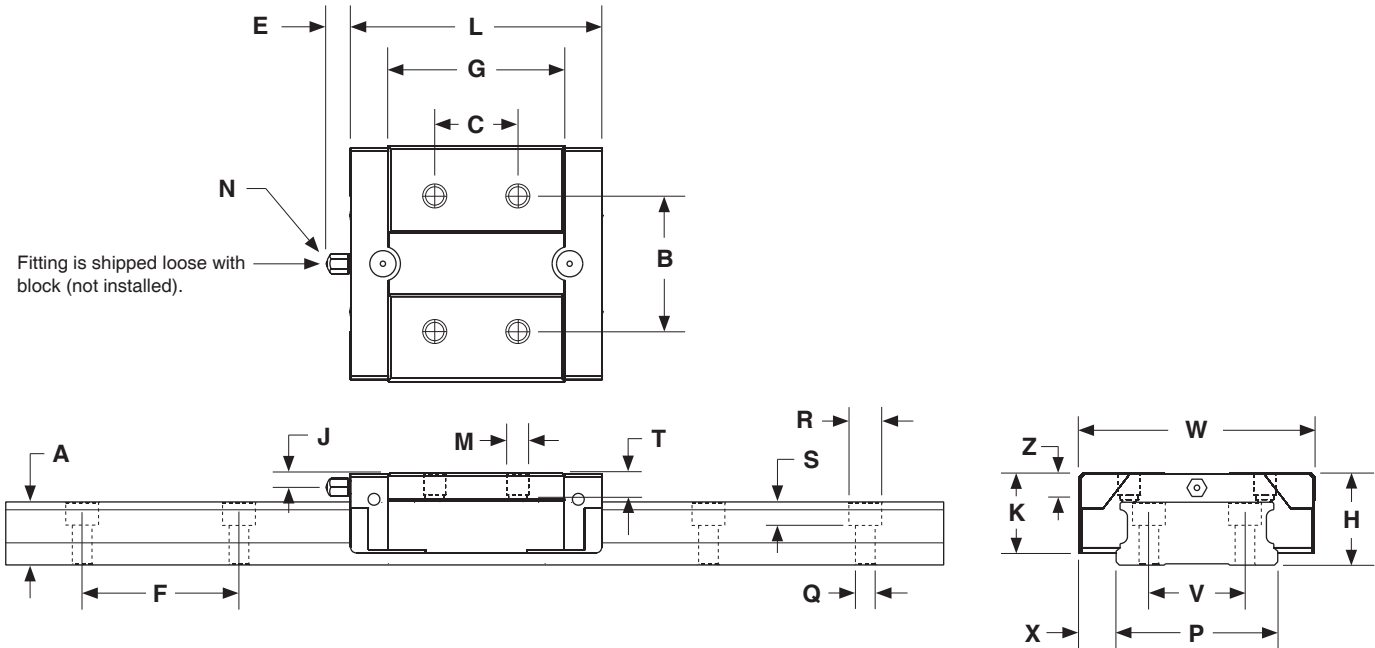

Rail Size	(mm)				
	D x Y	P	A	F	U
WRCU 21/15	M4 x 8	37	14.4	50	22
WRCU 27/20	M5 x 7.5	42	18.5	60	24

Rail Tapped from Bottom

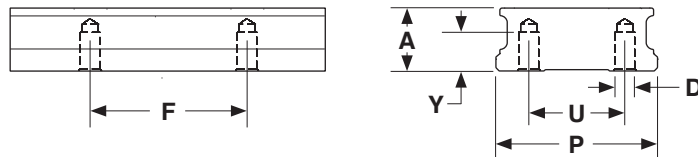

Model Number	Dynamic Load Capacity C ₅₀ (kN @ 50 km)		Static Load Capacity C ₀ (kN)		Static Moment Loads (Nm)					
	Standard	with Ball Chain	Standard	with Ball Chain	M _r		M _p		M _y	
					Standard	with Ball Chain	Standard	with Ball Chain	Standard	with Ball Chain
WRC 21/15 MN & FN	12.5	14.8	17.5	16.2	315	295	105	95	105	95
WRC 27/20 MN & FN	21.5	28.1	30.0	25.7	634	535	230	200	230	200

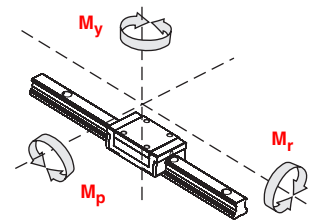

[More Information via the Web](#)

Dimensions & Specifications

Model Number	Outline (mm)			Block Dimensions (mm)									Rail Dimensions (mm)						Weight	
	Height H	Width W	Length L	B	C	M x T	K	G	Z	N	J	E	P	V	X	A	F	Q x R x S	Block (kg)	Rail (kg/m)
WRC 21/15 FN	21	68	57.5	60	29	M5 x 6	18.3	40.3	6	M3 x 6.5	3.3	3.5	37	22	15.5	14.4	50	4.5 x 7.5 x 5.3	0.20	3.60
WRC 27/20 FN	27	80	70	70	40	M6 x 9	23.5	52	9	M3 x 7.5	4.5	3.5	42	24	19	18.5	60	4.5 x 7.5 x 5.3	0.55	5.26

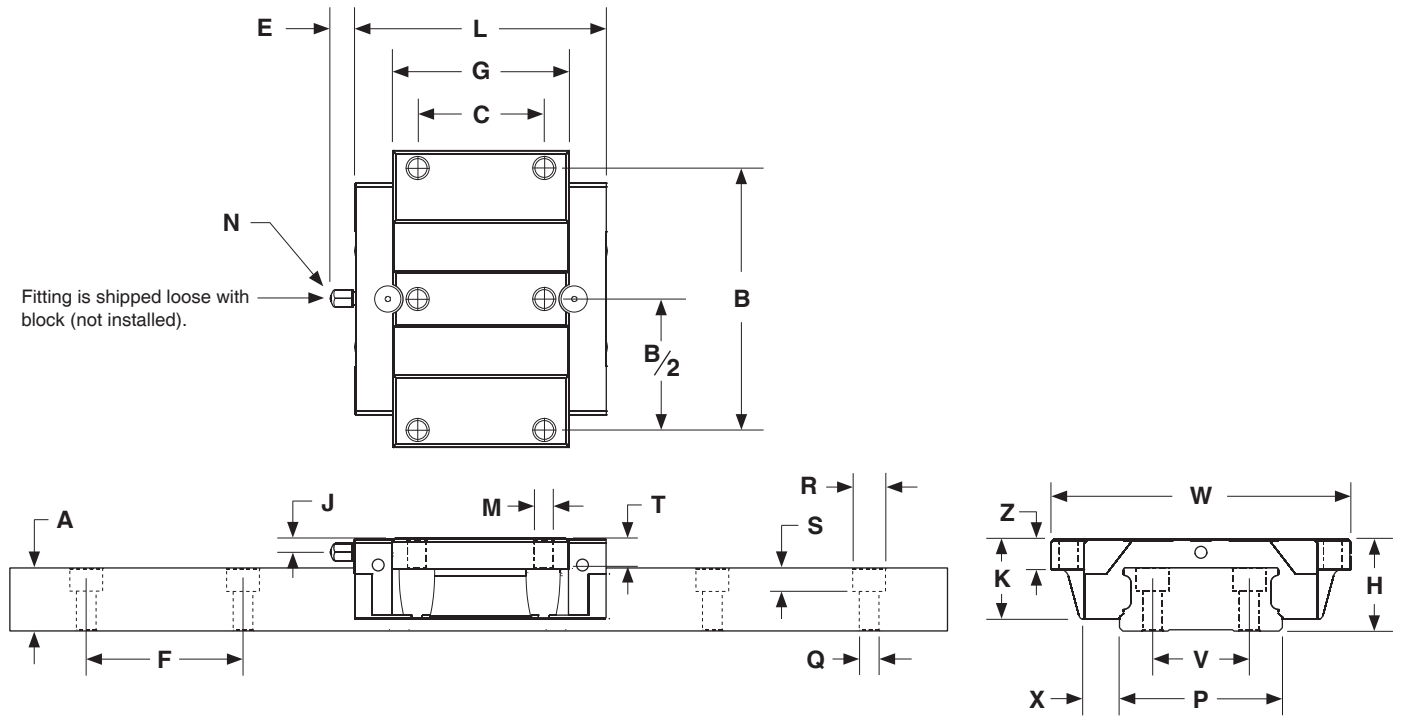

Rail Size	(mm)				
	D x Y	P	A	F	U
WRCU 21/15	M4 x 8	37	14.4	50	22
WRCU 27/20	M5 x 7.5	42	18.5	60	24

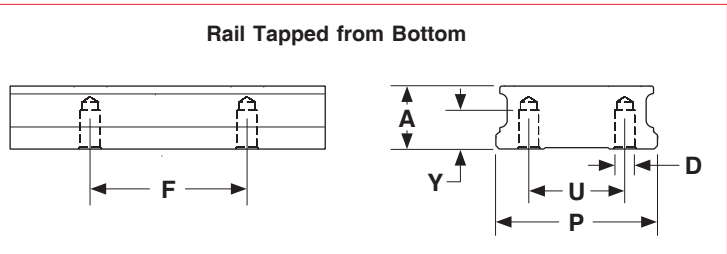

Model Number	Dynamic Load Capacity C ₅₀ (kN @ 50 km)		Static Load Capacity C ₀ (kN)		Static Moment Loads (Nm)					
	Standard	with Ball Chain	Standard	with Ball Chain	M _r		M _p		M _y	
WRC 21/15 MN & FN	12.5	14.8	17.5	16.2	Standard	with Ball Chain	Standard	with Ball Chain	Standard	with Ball Chain
WRC 27/20 MN & FN	21.5	28.1	30.0	25.7	315	295	105	95	105	95
					634	535	230	200	230	200

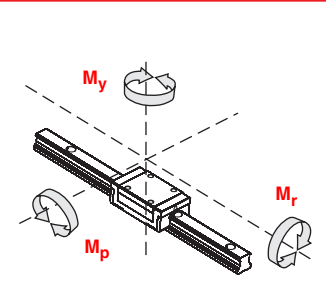

[More Information via the Web](#)

Dimensions & Specifications

Model Number	Outline (mm)			Block Dimensions (mm)											Rail Dimensions (mm)					Weight	
	Height H	Width W	Length L	B	C	M x T	K	G	N	J	E	O	Z	V	P	X	A	F	Q x R x S	Block (kg)	Rail (kg/m)
ARR 35 MN	48	70	122	50	50	M8 x 13	42	84	M6 x 12	10	12	M6 x 8	16	11	34	18	31	40	9 x 14 x 17	1.20	5.74
ARR 35 ML			147.5					109.5												17	
HRR 35 MN	55	70	122	50	50	M8 x 16	49	84	M6 x 12	17	12	M6 x 8	23	11	34	18	31	40	9 x 14 x 17	1.72	5.74
HRR 35 ML			147.5					109.5												17	

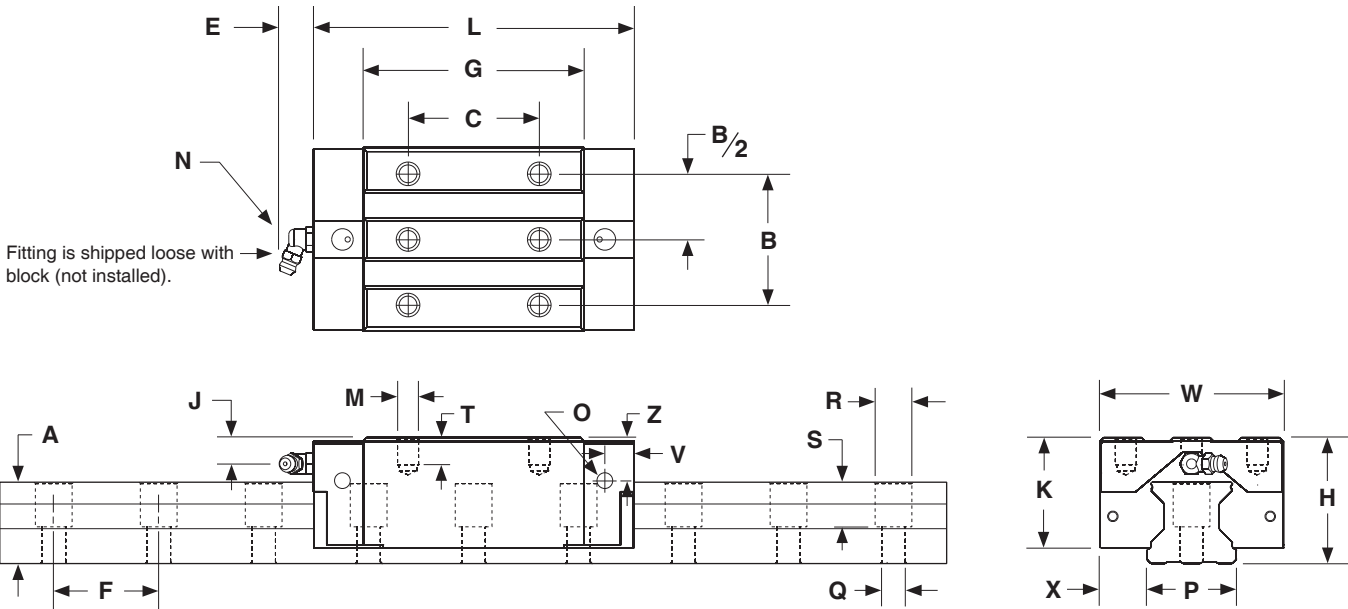

Rail Size	(mm)			
	D x Y	P	A	F
xRRU 35	M8 x 15	34	31	40

Rail Tapped from Bottom

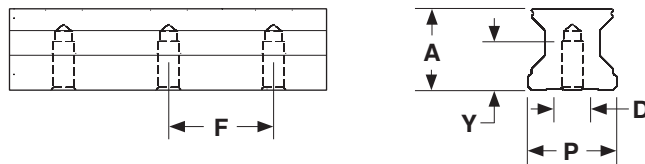

- A = ARRU rail
- H = HRRU rail

Model Number	Dynamic Load Capacity C ₅₀ (kN @ 50 km)		Static Load Capacity C ₀ (kN)		Static Moment Loads (Nm)					
	Standard	with Ball Chain	Standard	with Ball Chain	M _r		M _p		M _y	
					Standard	with Ball Chain	Standard	with Ball Chain	Standard	with Ball Chain
ARR 35 MN	71.8	89.8	154	133	2742	2350	1946	1710	1946	1710
HRR 35 MN										
HRR 35 FN										
ARR 35 ML	86.6	108.5	196	175	3525	3133	3226	2881	3226	2881
HRR 35 ML										
HRR 35 FL										

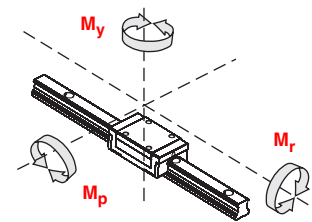

[More Information via the Web](#)

Dimensions & Specifications

Model Number	Outline (mm)			Block Dimensions (mm)													Rail Dimensions (mm)				
	Height H	Width W	Length L	B	C	U	M x T	M ₁ x T ₁	K	G	N	J	E	O	Z	V	P	X	A	F	Q x R x S
HRR 35 FN	48	100	122	82	52	62	M8 x 13	M10 x 13	42	84	M6 x 12	10	12	M6 x 8	16	11	34	33	31	40	9 x 14 x 17
HRR 35 FL			147.5							109.5											

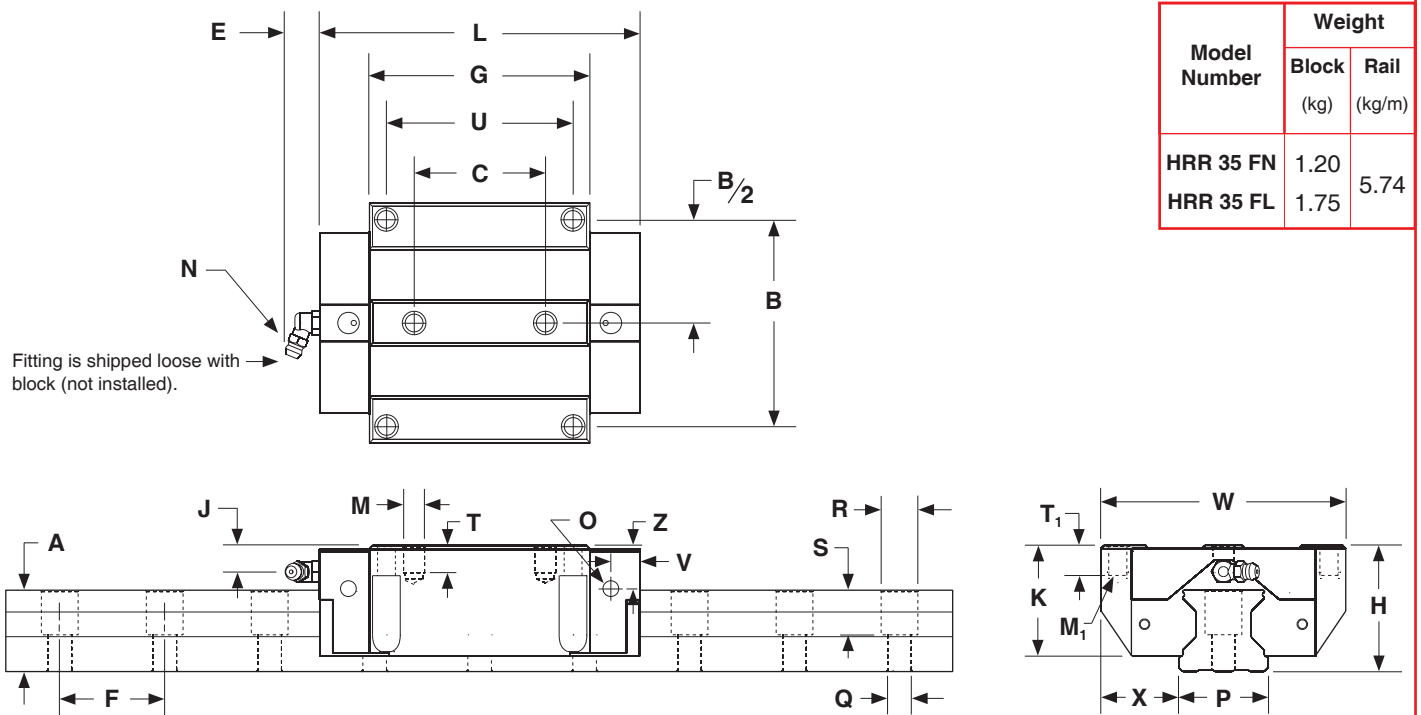

Model Number	Weight	
	Block (kg)	Rail (kg/m)
HRR 35 FN	1.20	5.74
HRR 35 FL	1.75	

Rail Size	(mm)			
	D x Y	P	A	F
HRRU 35	M8 x 15	34	31	40

Rail Tapped from Bottom

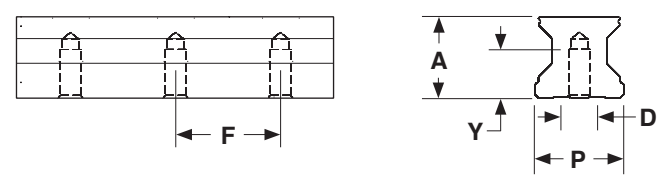

Model Number	Dynamic Load Capacity C ₅₀ (kN @ 50 km)		Static Load Capacity C ₀ (kN)		Static Moment Loads					
	Standard	with Ball Chain	Standard	with Ball Chain	M _r (Nm)		M _p (Nm)		M _y (Nm)	
					Standard	with Ball Chain	Standard	with Ball Chain	Standard	with Ball Chain
ARR 35 MN HRR 35 MN HRR 35 FN	71.8	89.8	154	133	2742	2350	1946	1710	1946	1710
ARR 35 ML HRR 35 ML HRR 35 FL	86.6	108.5	196	175	3525	3133	3226	2881	3226	2881

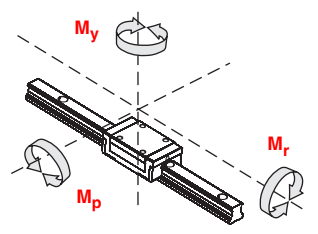

[More Information via the Web](#)

Features

RS Series

- * Rolled Ball Screw
- * Tapped Ball Nut
- * English Leads
- * English Diameters
- * Pre-loaded & Non-preloaded Nuts
- * Simple, Fixed and Rigid Housings
- * Available Screw Sizes
 - 0.500 inch dia., 0.200 inch lead
 - 0.500 inch dia., 0.500 inch lead
 - 0.625 inch dia., 0.200 inch lead
 - 0.625 inch dia., 1.000 inch lead
 - 0.750 inch dia., 0.200 inch lead
 - 0.750 inch dia., 0.500 inch lead
 - 1.000 inch dia., 0.250 inch lead
 - 1.000 inch dia., 0.500 inch lead
 - 1.000 inch dia., 1.000 inch lead
 - 1.500 inch dia., 0.250 inch lead
 - 1.500 inch dia., 0.500 inch lead
 - 1.500 inch dia., 1.000 inch lead
 - 1.500 inch dia., 2.000 inch lead

PS Series

- * Precision Rolled Ball Screw
- * Ground Ball Nut
- * English & Metric Leads
- * English & Metric Diameters
- * Pre-loaded & Non-preloaded Nuts
- * Simple, Fixed and Rigid Housings
- * Available Screw Sizes
 - 0.625 inch dia., 0.200 inch lead
 - 0.750 inch dia., 0.200 inch lead
 - 16 mm diameter, 5 mm lead
 - 16 mm diameter, 10 mm lead
 - 16 mm diameter, 16 mm lead
 - 20 mm diameter, 5 mm lead
 - 20 mm diameter, 20 mm lead

GS Series

- * Precision Ground Ball Screw
- * Ground Ball Nut
- * English & Metric Leads
- * English & Metric Diameters
- * Pre-loaded Nuts Only
- * Simple, Fixed and Rigid Housings
- * Available Screw Sizes
 - 0.625 inch dia., 0.200 inch lead
 - 0.750 inch dia., 0.200 inch lead
 - 16 mm diameter, 5 mm lead
 - 16 mm diameter, 16 mm lead
 - 20 mm diameter, 5 mm lead
 - 20 mm diameter, 20 mm lead

Features

Simple Support Housing

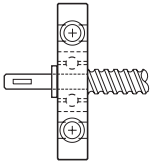

- * All Steel Construction
- * Black Oxide Finish
- * 1 Sealed Radial Bearing
- * No Lubrication Required
- * Base or Face Mounted

Fixed (LT) Support Housing

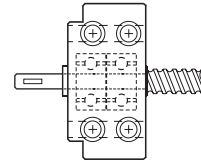

- * All Steel Construction
- * Black Oxide Finish
- * 2 Back to Back Sealed Radial Bearings
- * No Lubrication Required
- * Lip Seals
- * Base or Face Mounted
- * Motor Mount Options

Fixed (HT) Support Housing

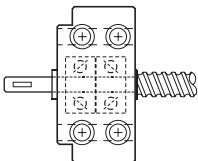

- * All Steel Construction
- * Black Oxide Finish
- * 2 Back to Back Angular Contact Bearings
- * No Lubrication Required
- * Lip Seals
- * Base or Face Mounted
- * Motor Mount Options

Rigid Support Housing

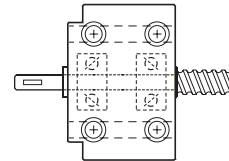

- * All Steel Construction
- * Black Oxide Finish
- * 2 Separated Angular Contact Bearings
- * No Lubrication Required
- * Lip Seals
- * Base or Face Mounted
- * Motor Mount Options

Simple-Simple

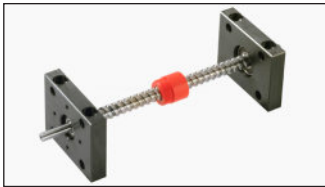

Fixed-Simple



Rigid-Simple

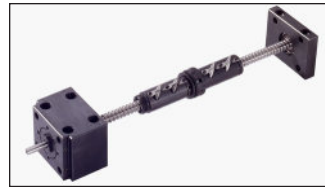

Rigid-Rigid



Screw & Nut Specifications

Model Number	Nut Type	Lead Error inch/ft (mm/300 mm)	Screw Efficiency %	Backlash inches (mm)	Static Load lbs (kgf)	Dynamic Load 1 million inches lbs (kgf)	Dynamic Load 100 million inches lbs (kgf)
RS050020 0.500 inch dia. 0.200 inch lead	<i>Non-preloaded Ball</i>	< 0.003 (0,075)	90	< 0.008 (0,203)	9,400 (4263)	1,200 (544)	290 (131)
	<i>Preloaded Ball</i>	< 0.003 (0,075)	90	0	9,280 (4209)	1,080 (489)	261 (118)
	<i>Non-preloaded Turcite</i>	< 0.003 (0,075)	60	< 0.008 (0,203)	800 (362)	100 (45)	24 (11)
	<i>Preloaded Turcite</i>	< 0.003 (0,075)	60	0	720 (326)	90 (41)	21 (10)
RS050050 0.500 inch dia. 0.500 inch lead	<i>Non-preloaded Ball</i>	< 0.003 (0,075)	90	< 0.008 (0,203)	13,350 (6055)	2,200 (997)	530 (240)
	<i>Preloaded Ball</i>	< 0.003 (0,075)	90	0	13,130 (5955)	1,980 (898)	477 (216)
	<i>Non-preloaded Turcite</i>	< 0.003 (0,075)	60	< 0.008 (0,203)	800 (362)	100 (45)	24 (11)
	<i>Preloaded Turcite</i>	< 0.003 (0,075)	60	0	720 (326)	90 (41)	21 (10)

Other Specifications

Maximum Acceleration Rate	Ball nut: 772 inches/sec ² (19.6 m/sec ²) Turcite nut: 193 inches/sec ² (4.9 m/sec ²)
Maximum Speed	Ball nut: 3000 rpm Turcite nut: 1500 rpm
Screw Material	Right Hand Thread, Case Hardened Rc 58 Steel Rolled Ball Screw
Screw Extensions	304 Woodruff Keyways on Extensions from Support Housings
Maximum Screw Stock Length	72 inches (1828 mm)
Screw Weight	0.66 lbs/ft (9,82 g/cm)
Support Housings	Steel with Black Oxide Finish, 45° Chamfer x .02 inch (0,50) all Straight Edges
Support Housing Features	Base or Face Mount with Integral Seals
Nut Flanges	Steel with Black Oxide Finish
Nut Flange Features	English or Metric Load Mounting Interface

[More Information via the Web](#)

Simple-Simple



Fixed-Simple



Rigid-Simple



Rigid-Rigid



Screw & Nut Specifications

Model Number	Nut Type	Lead Error inch/ft (mm/300 mm)	Screw Efficiency %	Backlash inches (mm)	Static Load lbs (kgf)	Dynamic Load 1 million inches lbs (kgf)	Dynamic Load 100 million inches lbs (kgf)
RS062020 0.625 inch dia. 0.200 inch lead	<i>Non-preloaded Ball</i>	< 0.003 (0,075)	90	< 0.008 (0,203)	7,450 (3379)	800 (363)	190 (86)
	<i>Preloaded Ball</i>	< 0.003 (0,075)	90	0	6,070 (2753)	720 (326)	171 (78)
	<i>Non-preloaded Turcite</i>	< 0.003 (0,075)	60	< 0.008 (0,203)	800 (362)	100 (45)	24 (11)
	<i>Preloaded Turcite</i>	< 0.003 (0,075)	60	0	720 (326)	90 (41)	21 (10)
RS062100 0.625 inch dia. 1.000 inch lead	<i>Non-preloaded Ball</i>	< 0.004 (0,099)	90	< 0.008 (0,203)	2,425 (1100)	590 (268)	140 (64)
	<i>Preloaded Ball</i>	< 0.004 (0,099)	90	0	2,425 (1100)	531 (241)	126 (57)
	<i>Non-preloaded Turcite</i>	< 0.004 (0,099)	60	< 0.008 (0,203)	800 (362)	100 (45)	24 (11)
	<i>Preloaded Turcite</i>	< 0.004 (0,099)	60	0	720 (326)	90 (41)	21 (10)

Other Specifications

Maximum Acceleration Rate	Ball nut: 772 inches/sec ² (19.6 m/sec ²) Turcite nut: 193 inches/sec ² (4.9 m/sec ²)
Maximum Speed	Ball nut: 3000 rpm Turcite nut: 1500 rpm
Screw Material	Right Hand Thread, Case Hardened Rc 58 Steel Rolled Ball Screw
Screw Extensions	304 Woodruff Keyways on Extensions from Support Housings
Maximum Screw Stock Length	72 inches (1828 mm)
Screw Weight	0.92 lbs/ft (13,7 g/cm)
Support Housings	Steel with Black Oxide Finish, 45° Chamfer x .02 inch (0,50) all Straight Edges
Support Housing Features	Base or Face Mount with Integral Seals
Nut Flanges	Steel with Black Oxide Finish
Nut Flange Features	English or Metric Load Mounting Interface

[More Information via the Web](#)

Simple-Simple



Fixed-Simple

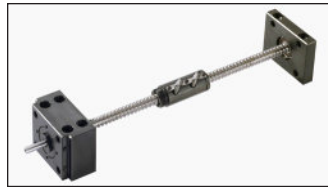

Rigid-Simple

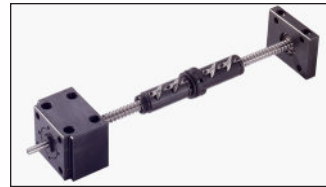

Rigid-Rigid



Screw & Nut Specifications

Model Number	Nut Type	Lead Error inch/ft (mm/300 mm)	Screw Efficiency %	Backlash inches (mm)	Static Load lbs (kgf)	Dynamic Load 1 million inches lbs (kgf)	Dynamic Load 100 million inches lbs (kgf)
RS075020 0.750 inch dia. 0.200 inch lead	<i>Non-preloaded Ball</i>	< 0.003 (0,075)	90	< 0.008 (0,203)	18,800 (8527)	1,900 (862)	460 (208)
	<i>Preloaded Ball</i>	< 0.003 (0,075)	90	0	18,610 (8441)	1,710 (776)	414 (188)
	<i>Non-preloaded Turcite</i>	< 0.003 (0,075)	60	< 0.008 (0,203)	1,500 (680)	195 (88)	45 (20)
	<i>Preloaded Turcite</i>	< 0.003 (0,075)	60	0	1350 (612)	175 (79)	40 (18)
RS075050 0.750 inch dia. 0.500 inch lead	<i>Non-preloaded Ball</i>	< 0.003 (0,075)	90	< 0.008 (0,203)	24,200 (10977)	3,450 (1565)	820 (372)
	<i>Preloaded Ball</i>	< 0.003 (0,075)	90	0	23,855 (10820)	3,105 (1408)	738 (335)
	<i>Non-preloaded Turcite</i>	< 0.003 (0,075)	60	< 0.008 (0,203)	1,500 (680)	195 (88)	45 (20)
	<i>Preloaded Turcite</i>	< 0.003 (0,075)	60	0	1,350 (612)	175 (79)	40 (18)

Other Specifications

Maximum Acceleration Rate	Ball nut: 772 inches/sec ² (19.6 m/sec ²) Turcite nut: 193 inches/sec ² (4.9 m/sec ²)
Maximum Speed	Ball nut: 3000 rpm Turcite nut: 1500 rpm
Screw Material	Right Hand Thread, Case Hardened Rc 58 Steel Rolled Ball Screw
Screw Extensions	304 Woodruff Keyways on Extensions from Support Housings
Maximum Screw Stock Length	72 inches (1828 mm)
Screw Weight	1.42 lbs/ft (21,1 g/cm)
Support Housings	Steel with Black Oxide Finish, 45° Chamfer x .02 inch (0,50) all Straight Edges
Support Housing Features	Base or Face Mount with Integral Seals
Nut Flanges	Steel with Black Oxide Finish
Nut Flange Features	English or Metric Load Mounting Interface

[More Information via the Web](#)

Simple-Simple



Fixed-Simple



Rigid-Simple



Rigid-Rigid



Screw & Nut Specifications

[More Information via the Web](#)

Model Number	Nut Type	Lead Error inch/ft (mm/300 mm)	Screw Efficiency %	Backlash inches (mm)	Static Load lbs (kgf)	Dynamic Load 1 million inches lbs (kgf)	Dynamic Load 100 million inches lbs (kgf)
RS100025 1.000 inch dia. 0.250 inch lead	<i>Non-preloaded Ball</i>	< 0.009 (0,229)	90	< 0.009 (0,229)	30,750 (13947)	3,350 (1519)	810 (367)
	<i>Preloaded Ball</i>	< 0.009 (0,229)	90	0	30,415 (13796)	3,015 (1367)	729 (330)
	<i>Non-preloaded Turcite</i>	< 0.009 (0,229)	60	< 0.009 (0,229)	1,500 (380)	195 (88)	45 (20)
	<i>Preloaded Turcite</i>	< 0.009 (0,229)	60	0	1,350 (612)	175 (79)	40 (18)
RS100050 1.000 inch dia. 0.500 inch lead	<i>Non-preloaded Ball</i>	< 0.009 (0,229)	90	< 0.009 (0,229)	32,300 (14650)	3,950 (1792)	970 (440)
	<i>Preloaded Ball</i>	< 0.009 (0,229)	90	0	31,905 (14471)	3,555 (1612)	873 (396)
	<i>Non-preloaded Turcite</i>	< 0.009 (0,229)	60	< 0.009 (0,229)	1,500 (680)	195 (88)	45 (20)
	<i>Preloaded Turcite</i>	< 0.009 (0,229)	60	0	1,350 (612)	175 (79)	40 (18)
RS100100 1.000 inch dia. 1.000 inch lead	<i>Non-preloaded Ball</i>	< 0.009 (0,229)	90	< 0.009 (0,229)	13,750 (6236)	2,250 (1020)	560 (254)
	<i>Preloaded Ball</i>	< 0.009 (0,229)	90	0	13,525 (6134)	2,025 (918)	504 (229)
	<i>Non-preloaded Turcite</i>	< 0.009 (0,229)	60	< 0.009 (0,229)	1,500 (680)	195 (88)	45 (20)
	<i>Preloaded Turcite</i>	< 0.009 (0,229)	60	0	1,350 (612)	175 (79)	40 (18)

Other Specifications

Maximum Acceleration Rate	Ball nut: 772 inches/sec ² (19.6 m/sec ²) Turcite nut: 193 inches/sec ² (4.9 m/sec ²)
Maximum Speed	Ball nut: 3000 rpm Turcite nut: 1500 rpm
Screw Material	Right Hand Thread, Case Hardened Rc 58 Steel Rolled Ball Screw
Screw Extensions	605 Woodruff Keyways on Extensions from Support Housings
Maximum Screw Stock Length	144 inches (3657 mm)
Screw Weight	2.23 lbs/ft (34,7 g/cm)
Support Housings	Steel with Black Oxide Finish, 45° Chamfer x .03 inch (0,76) all Straight Edges
Support Housing Features	Base or Face Mount with Integral Seals
Nut Flanges	Steel with Black Oxide Finish
Nut Flange Features	English or Metric Load Mounting Interface

Simple-Simple

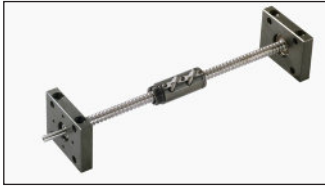

Fixed-Simple

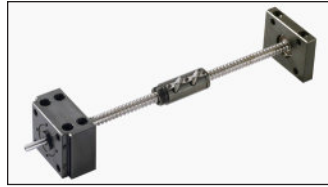

Rigid-Simple

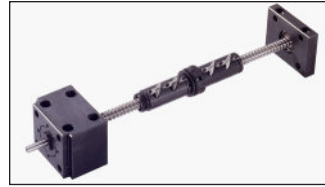

Rigid-Rigid



Screw & Nut Specifications

Model Number	Nut Type	Lead Error inch/ft (mm/300 mm)	Screw Efficiency %	Backlash inches (mm)	Static Load lbs (kgf)	Dynamic Load 1 million inches lbs (kgf)	Dynamic Load 100 million inches lbs (kgf)
RS150025 1.500 inch dia. 0.250 inch lead	<i>Non-preloaded Ball</i>	< 0.013 (0,330)	90	< 0.009 (0,229)	47,450 (21523)	4,050 (1837)	970 (440)
	<i>Preloaded Ball</i>	< 0.013 (0,330)	90	0	47,045 (21339)	3,645 (1653)	873 (396)
RS150050 1.500 inch dia. 0.500 inch lead	<i>Non-preloaded Ball</i>	< 0.013 (0,330)	90	< 0.009 (0,229)	102,300 (46402)	12,900 (5851)	3,100 (1406)
	<i>Preloaded Ball</i>	< 0.013 (0,330)	90	0	101,010 (45817)	11,610 (5266)	2,790 (1266)
RS150100 1.500 inch dia. 1.000 inch lead	<i>Non-preloaded Ball</i>	< 0.013 (0,330)	90	< 0.009 (0,229)	47,800 (21682)	8,250 (3742)	2,020 (916)
	<i>Preloaded Ball</i>	< 0.013 (0,330)	90	0	46,975 (21307)	7,425 (3368)	1,818 (825)
RS150200 1.500 inch dia. 2.000 inch lead	<i>Non-preloaded Ball</i>	< 0.013 (0,330)	90	< 0.009 (0,229)	31,250 (14175)	7,600 (3447)	1,850 (839)
	<i>Preloaded Ball</i>	< 0.013 (0,330)	90	0	28,240 (12809)	6,840 (3103)	1,665 (755)

Other Specifications

Maximum Acceleration Rate	Ball nut: 772 inches/sec ² (19.6 m/sec ²)
Maximum Speed	Ball nut: 3000 rpm
Screw Material	Right Hand Thread, Case Hardened Rc 58 Steel Rolled Ball Screw
Screw Extensions	605 Woodruff Keyways on Extensions from Support Housings
Maximum Screw Stock Length	144 inches (3657 mm)
Screw Weight	5.58 lbs/ft (83,1 g/cm)
Support Housings	Steel with Black Oxide Finish, 45° Chamfer x .03 inch (0,76) all Straight Edges
Support Housing Features	Base or Face Mount with Integral Seals
Nut Flanges	Steel with Black Oxide Finish
Nut Flange Features	English or Metric Load Mounting Interface

[More Information via the Web](#)

Simple-Simple

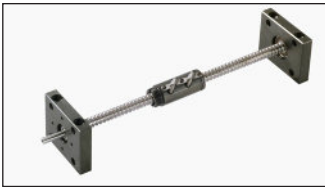

Fixed-Simple



Rigid-Simple



Rigid-Rigid



Screw & Nut Specifications

Model Number	Nut Type	Lead Error inch/ft (mm/300 mm)	Screw Efficiency %	Backlash inches (mm)	Static Load lbs (kgf)	Dynamic Load 1 million inches lbs (kgf)	Dynamic Load 100 million inches lbs (kgf)
PS062020 0.625 inch dia. 0.200 inch lead	<i>Non-preloaded Ball</i>	< 0.002 (0,050)	90	< 0.003 (0,076)	2,700 (1224)	876 (397)	190 (86)
	<i>Preloaded Ball</i>	< 0.002 (0,050)	90	0	2,430 (1102)	788 (357)	171 (78)
PS16M05M 16 mm dia. 5 mm lead	<i>Non-preloaded Ball</i>	< 0.002 (0,050)	90	< 0.003 (0,076)	2,700 (1224)	876 (397)	190 (86)
	<i>Preloaded Ball</i>	< 0.002 (0,050)	90	0	2,430 (1102)	788 (357)	171 (78)
PS16M10M 16 mm dia. 10 mm lead	<i>Non-preloaded Ball</i>	< 0.002 (0,050)	90	< 0.003 (0,076)	2,630 (1192)	1,080 (489)	235 (106)
	<i>Preloaded Ball</i>	< 0.002 (0,050)	90	0	2,365 (1072)	972 (440)	211 (95)
PS16M16M 16 mm dia. 16 mm lead	<i>Non-preloaded Ball</i>	< 0.002 (0,050)	90	< 0.003 (0,076)	1,620 (734)	819 (371)	179 (81)
	<i>Preloaded Ball</i>	< 0.002 (0,050)	90	0	1,455 (659)	737 (334)	161 (73)

Other Specifications

Maximum Acceleration Rate	Ball nut: 772 inches/sec ² (19.6 m/sec ²)
Maximum Speed	Ball nut: 3000 rpm
Screw Material	Right Hand Thread, Case Hardened Rc 58 Steel Rolled Ball Screw
Screw Extensions	304 Woodruff Keyways on Extensions from Support Housings
Maximum Screw Stock Length	78.74 inches (2000 mm)
Screw Weight	0.87 lbs/ft (13,0 g/cm)
Support Housings	Steel with Black Oxide Finish, 45° Chamfer x .02 inch (0,50) all Straight Edges
Support Housing Features	Base or Face Mount with Integral Seals
Nut Flanges	Steel with Black Oxide Finish
Nut Flange Features	English or Metric Load Mounting Interface

[More Information via the Web](#)

Simple-Simple

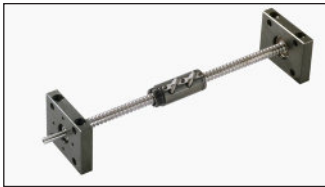

Fixed-Simple

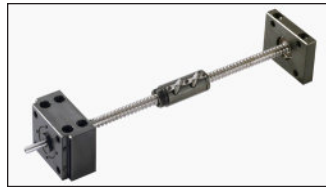

Rigid-Simple

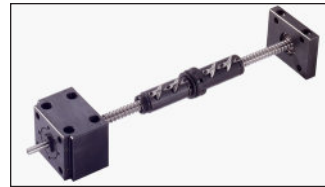

Rigid-Rigid



Screw & Nut Specifications

Model Number	Nut Type	Lead Error inch/ft (mm/300 mm)	Screw Efficiency %	Backlash inches (mm)	Static Load lbs (kgf)	Dynamic Load 1 million inches lbs (kgf)	Dynamic Load 100 million inches lbs (kgf)
PS075020 0.750 inch dia. 0.200 inch lead	<i>Non-preloaded Ball</i>	< 0.002 (0,050)	90	< 0.003 (0,076)	3,360 (1524)	964 (437)	210 (95)
	<i>Preloaded Ball</i>	< 0.002 (0,050)	90	0	3,025 (1372)	867 (393)	189 (86)
PS20M05M 20 mm dia. 5 mm lead	<i>Non-preloaded Ball</i>	< 0.002 (0,050)	90	< 0.003 (0,076)	3,990 (1809)	1,070 (485)	234 (106)
	<i>Preloaded Ball</i>	< 0.002 (0,050)	90	0	3,590 (1628)	960 (435)	210 (95)
PS20M20M 20 mm dia. 20 mm lead	<i>Non-preloaded Ball</i>	< 0.002 (0,050)	90	< 0.003 (0,076)	3,505 (1589)	1,293 (586)	283 (128)
	<i>Preloaded Ball</i>	< 0.002 (0,050)	90	0	3,150 (1428)	1,160 (526)	255 (116)

Other Specifications

Maximum Acceleration Rate	Ball nut: 772 inches/sec ² (19,6 m/sec ²)
Maximum Speed	Ball nut: 3000 rpm
Screw Material	Right Hand Thread, Case Hardened Rc 58 Steel Precision Rolled Ball Screw
Screw Extensions	304 Woodruff Keyways on Extensions from Support Housings
Maximum Screw Stock Length	118.11 inches (3000 mm)
Screw Weight	1.35 lbs/ft (20,1 g/cm)
Support Housings	Steel with Black Oxide Finish, 45° Chamfer x .02 inch (0,50) all Straight Edges
Support Housing Features	Base or Face Mount with Integral Seals
Nut Flanges	Steel with Black Oxide Finish
Nut Flange Features	English or Metric Load Mounting Interface

[More Information via the Web](#)

Simple-Simple

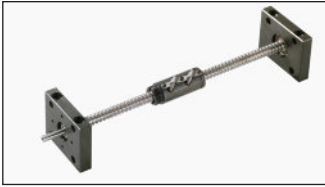

Fixed-Simple

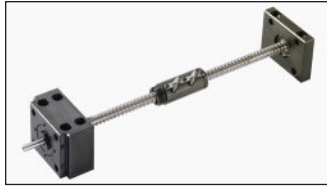

Rigid-Simple

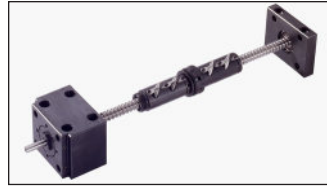

Rigid-Rigid



Screw & Nut Specifications

Model Number	Nut Type	Lead Error inch/ft (mm/300 mm)	Screw Efficiency %	Backlash inches (mm)	Static Load lbs (kgf)	Dynamic Load 1 million inches lbs (kgf)	Dynamic Load 100 million inches lbs (kgf)
GS062020 0.625 inch dia. 0.200 inch lead	<i>Preloaded Ball</i>	< 0.0005 (0,012)	90	0	3,080 (1397)	987 (447)	216 (97)
GS16M05M 16 mm dia. 5 mm lead	<i>Preloaded Ball</i>	< 0.0005 (0,012)	90	0	3,080 (1397)	987 (447)	216 (97)
GS16M16M 16 mm dia. 16 mm lead	<i>Preloaded Ball</i>	< 0.0005 (0,012)	90	0	1,800 (816)	910 (816)	199 (90)

Other Specifications

Maximum Acceleration Rate	Ball nut: 772 inches/sec ² (19,6 m/sec ²)
Maximum Speed	Ball nut: 3000 rpm
Screw Material	Right Hand Thread, Case Hardened Rc 58 Steel Precision Rolled Ball Screw
Screw Extensions	304 Woodruff Keyways on Extensions from Support Housings
Maximum Screw Stock Length	45.27 inches (1150 mm)
Screw Weight	0.87 lbs/ft (13,0 g/cm)
Support Housings	Steel with Black Oxide Finish, 45° Chamfer x .02 inch (0,50) all Straight Edges
Support Housing Features	Base or Face Mount with Integral Seals
Nut Flanges	Steel with Black Oxide Finish
Nut Flange Features	English or Metric Load Mounting Interface

[More Information via the Web](#)

Simple-Simple

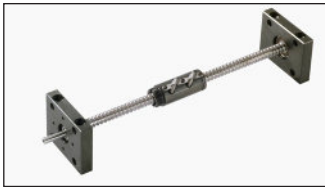

Fixed-Simple

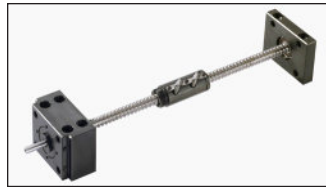

Rigid-Simple



Rigid-Rigid



Screw & Nut Specifications

Model Number	Nut Type	Lead Error inch/ft (mm/300 mm)	Screw Efficiency %	Backlash inches (mm)	Static Load lbs (kgf)	Dynamic Load 1 million inches lbs (kgf)	Dynamic Load 100 million inches lbs (kgf)
GS075020 0.750 inch dia. 0.200 inch lead	<i>Preloaded Ball</i>	< 0.0005 (0,012)	90	0	3,990 (1809)	1,070 (485)	234 (106)
GS20M05M 20 mm dia. 5 mm lead	<i>Preloaded Ball</i>	< 0.0005 (0,012)	90	0	3,990 (1809)	1,070 (485)	234 (106)
GS20M20M 20 mm dia. 20 mm lead	<i>Preloaded Ball</i>	< 0.0005 (0,012)	90	0	3,505 (1589)	1,293 (586)	283 (128)

Other Specifications

Maximum Acceleration Rate	Ball nut: 772 inches/sec ² (19,6 m/sec ²)
Maximum Speed	Ball nut: 3000 rpm
Screw Material	Right Hand Thread, Case Hardened Rc 58 Steel Precision Rolled Ball Screw
Screw Extensions	304 Woodruff Keyways on Extensions from Support Housings
Maximum Screw Stock Length	64.95 inches (1650 mm)
Screw Weight	1.35 lbs/ft (20,1 g/cm)
Support Housings	Steel with Black Oxide Finish, 45° Chamfer x .02 inch (0,50) all Straight Edges
Support Housing Features	Base or Face Mount with Integral Seals
Nut Flanges	Steel with Black Oxide Finish
Nut Flange Features	English or Metric Load Mounting Interface

[More Information via the Web](#)

Standard Features

- ❑ Compact 2.875 inches (73 mm) wide by 2.375 inches (60 mm) tall
- ❑ Travel lengths from 2 inches (50 mm) to 60 inches (1520 mm)
- ❑ Threaded stainless steel inserts in carriage for load mounting
- ❑ 0° F to +185° F (-18° C to +85° C) operating temperature
- ❑ Recirculating linear ball bearing system
- ❑ Precision ground square rail design
- ❑ 1 rail, 1 or 2 bearing carriages

130-CP0 series

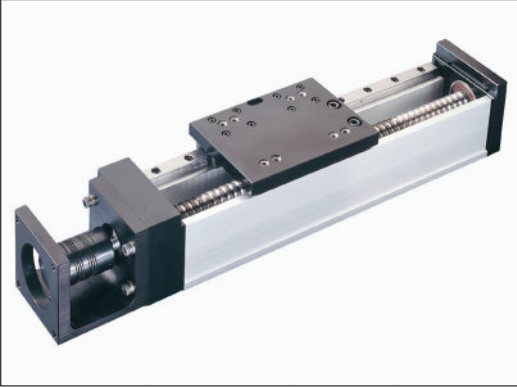

130-CP1 series

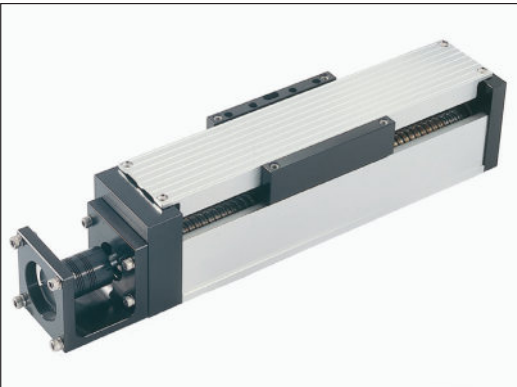

130-CP2 series



Options

- ❑ Chrome plated linear bearings, rails and screws
- ❑ End of travel (EOT) and home switches wired
- ❑ Adapter brackets for NEMA & Metric motors
- ❑ CAD drawings available via our Website
- ❑ Linear and rotary incremental encoders
- ❑ Power-off electric brakes
- ❑ Carriage adapter plates
- ❑ Vertical angle brackets
- ❑ Motor wrap packages
- ❑ Turcite nut options
- ❑ Motor couplings
- ❑ Cover plates
- ❑ Hand crank

❑ Ball screws:

Rolled - Non-preloaded & Preloaded Nuts:

0.625 inch diameter, 0.200 inch lead

* 0.500 inch diameter, 0.500 inch lead

0.625 inch diameter, 1.000 inch lead

Precision - Non-preloaded & Preloaded Nuts:

0.625 inch diameter, 0.200 inch lead

16 mm diameter, 5 mm lead

* 16 mm diameter, 10 mm lead

* 16 mm diameter, 16 mm lead

Ground - Preloaded Nuts Only:

0.625 inch diameter, 0.200 inch lead

16 mm diameter, 5 mm lead

16 mm diameter, 16 mm lead

* (Reduction of travel with preloaded nut)

❑ Acme screws:

Rolled - Non-preloaded & Preloaded Nuts:

0.625 inch diameter, 0.100 inch lead

0.625 inch diameter, 0.200 inch lead

16 mm diameter, 4 mm lead

Specifications

Load Capacities		One (1) Bearing Carriage	Two (2) Bearing Carriage
Dynamic Horizontal	2 million inches (50 km) of travel	100 lbs (45 kg)	200 lbs (90 kg)
Dynamic Horizontal	100 million inches (2540 km) of travel	27 lbs (12 kg)	54 lbs (24 kg)
Static Horizontal		200 lbs (90 kg)	400 lbs (180 kg)
Dynamic Roll Moment	2 million inches (50 km) of travel	8 ft-lbs (11 N-m)	16 ft-lbs (22 N-m)
Dynamic Roll Moment	100 million inches (2540 km) of travel	2 ft-lbs (3 N-m)	4 ft-lbs (5 N-m)
Static Roll Moment		14 ft-lbs (19 N-m)	28 ft-lbs (38 N-m)
Dyn. Pitch & Yaw Moment	2 million inches (50 km) of travel	4 ft-lbs (5,4 N-m)	15 ft-lbs (20 N-m)
Dyn. Pitch & Yaw Moment	100 million inches (2540 km) of travel	1 ft-lbs (1,5 N-m)	4 ft-lbs (5 N-m)
Static Pitch & Yaw Moment		8 ft-lbs (10 N-m)	30 ft-lbs (40 N-m)
Each Bearing Dyn. Capacity	2 million inches (50 km) of travel	100 lbs (45 kg)	100 lbs (45 kg)
Each Bearing Dyn. Capacity	100 million inches (2540 km) of travel	27 lbs (12 kg)	27 lbs (12 kg)
Each Bearing Static Load Capacity		200 lbs (90 kg)	200 lbs (90 kg)
Thrust Force Capacity	10 million screw revolutions	665 lbs (302 kg)	665 lbs (302 kg)
Thrust Force Capacity	500 million screw revolutions	180 lbs (82 kg)	180 lbs (82 kg)
Maximum Acceleration		50 in/sec ² (1,3 m/sec ²)	150 in/sec ² (3,8 m/sec ²)
d₂	Center to center distance (spacing) of each bearing on a single rail	-	2.088 in (53,0 mm)
d_r	CP0 version Center distance of the bearing to top of carriage plate surface	0.750 in (19,1 mm)	0.750 in (19,1 mm)
d_r	CP1 version Center distance of the bearing to top of carriage plate surface	1.375 in (34,9 mm)	1.375 in (34,9 mm)

Other	For One (1) & Two (2) Bearing Carriages
Table Material	Base, Carriage, End Plates, & Cover Plate option - 6061 anodized aluminum
Linear Rail Material	Stainless Steel
Screw Material	Acme Screw - Stainless Steel
Screw Material	Rolled Ball, Precision Ball, & Ground Ball - Case Hardened Steel
Unidirectional Repeatability	+/- 0.0001 in (2,5 microns) to +/- 0.0002 in (5 microns) - depends on selected screw
Bidirectional Repeatability	+/- 0.0001 in (2,5 microns) to +/- 0.0082 in (208 microns) - depends on selected screw
Straightness	< 0.00013 in/in (< 3,30 microns/25mm)
Flatness	< 0.00013 in/in (< 3,30 microns/25mm)
Orthogonality (multi-axis systems)	< 30 arc-seconds
Friction Coefficient	< 0.01
Motor Mount	NEMA 23 & 34 Mounts, Metric Mounts, Motor Wraps, and Hand Crank Option
Coupling	Three (3) different styles available

[More Information via the Web](#)

Standard Features

- ❑ Compact 3.50 inches (89 mm) wide by 2.375 inches (60 mm) tall - 100 series
- ❑ Compact 5.25 inches (133 mm) wide by 2.375 inches (60 mm) tall - 110 series
- ❑ Travel lengths from 2 inches (50 mm) to 60 inches (1520 mm)
- ❑ Threaded stainless steel inserts in carriage for load mounting
- ❑ 0° F to +185° F (-18° C to +85° C) operating temperature
- ❑ Recirculating linear ball bearing system
- ❑ Precision ground square rail design
- ❑ 2 rails, 2 or 4 bearing carriages

100-CP0 series

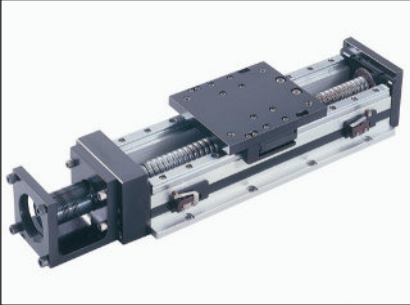

100-CP1 series

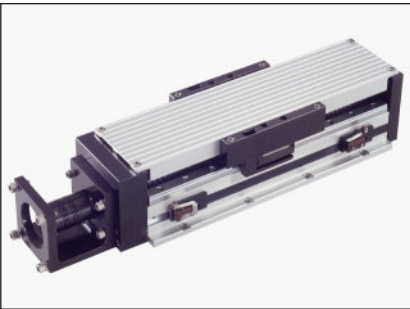

100-CP2 series

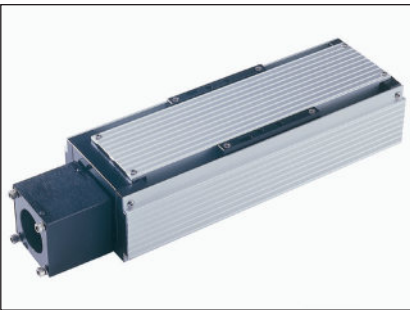

110-WC1 series

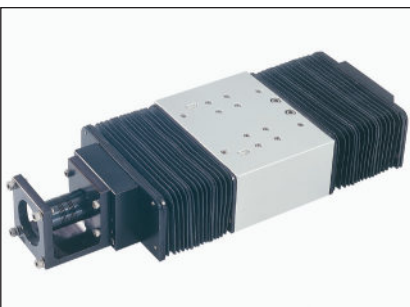

Options

- ❑ Chrome plated linear bearings, rails and screws
- ❑ End of travel (EOT) and home switches wired
- ❑ Adapter brackets for NEMA & Metric motors
- ❑ CAD drawings available via our Website
- ❑ Linear and rotary incremental encoders
- ❑ Power-off electric brakes
- ❑ Carriage adapter plates
- ❑ Vertical angle brackets
- ❑ Motor wrap packages
- ❑ Turcite nut options
- ❑ Motor couplings
- ❑ Cover plates
- ❑ Hand crank
- ❑ Waycovers

❑ Ball screws:

Rolled - Non-preloaded & Preloaded Nuts:

- 0.625 inch diameter, 0.200 inch lead
- * 0.500 inch diameter, 0.500 inch lead
- 0.625 inch diameter, 1.000 inch lead

Precision - Non-preloaded & Preloaded Nuts:

- 0.625 inch diameter, 0.200 inch lead
- 16 mm diameter, 5 mm lead
- * 16 mm diameter, 10 mm lead
- * 16 mm diameter, 16 mm lead

Ground - Preloaded Nuts Only:

- 0.625 inch diameter, 0.200 inch lead
- 16 mm diameter, 5 mm lead
- 16 mm diameter, 16 mm lead

* (Reduction of travel with preloaded nut)

❑ Acme screws:

Rolled - Non-preloaded & Preloaded Nuts:

- 0.625 inch diameter, 0.100 inch lead
- 0.625 inch diameter, 0.200 inch lead
- 16 mm diameter, 4 mm lead

Specifications

Load Capacities		Two (2) Bearing Carriage		Four (4) Bearing Carriage	
Dynamic Horizontal	2 million inches (50 km) of travel	1,550 lbs	(703 kg)	3,100 lbs	(1406 kg)
Dynamic Horizontal	100 million inches (2540 km) of travel	415 lbs	(188 kg)	840 lbs	(381 kg)
Static Horizontal		2,360 lbs	(1070 kg)	4,720 lbs	(2140 kg)
Dynamic Roll Moment	2 million inches (50 km) of travel	140 ft-lbs	(190 N-m)	280 ft-lbs	(379 N-m)
Dynamic Roll Moment	100 million inches (2540 km) of travel	37 ft-lbs	(50 N-m)	75 ft-lbs	(101 N-m)
Static Roll Moment		210 ft-lbs	(285 N-m)	425 ft-lbs	(576 N-m)
Dyn. Pitch & Yaw Moment	2 million inches (50 km) of travel	18 ft-lbs	(24 N-m)	240 ft-lbs	(325 N-m)
Dyn. Pitch & Yaw Moment	100 million inches (2540 km) of travel	5 ft-lbs	(7 N-m)	65 ft-lbs	(88 N-m)
Static Pitch & Yaw Moment		30 ft-lbs	(41 N-m)	365 ft-lbs	(495 N-m)
Each Bearing Dyn. Capacity	2 million inches (50 km) of travel	775 lbs	(351 kg)	775 lbs	(351 kg)
Each Bearing Dyn. Capacity	100 million inches (2540 km) of travel	208 lbs	(94 kg)	208 lbs	(94 kg)
Each Bearing Static Load Capacity		1,180 lbs	(535 kg)	1,180 lbs	(535 kg)
Thrust Force Capacity	10 million screw revolutions	665 lbs	(302 kg)	665 lbs	(302 kg)
Thrust Force Capacity	500 million screw revolutions	180 lbs	(82 kg)	180 lbs	(82 kg)
Maximum Acceleration		386 in/sec ²	(9,8 m/sec ²)	772 in/sec ²	(19,6 m/sec ²)
d₁	Center to center distance (spread) between the two rails	2.375 in	(60,3 mm)	2.375 in	(60,3 mm)
d₂	Center to center distance (spacing) of the bearings on a single rail	-		2.088 in	(53,0 mm)
d_r	CP0 version Center distance of the bearing to top of carriage plate surface	.750 in	(19,1 mm)	.750 in	(19,1 mm)
d_r	CP1 version Center distance of the bearing to top of carriage plate surface	1.375 in	(34,9 mm)	1.375 in	(34,9 mm)

Other	For Two (2) & Four (4) Bearing Carriages
Table Material	Base, Carriage, End Plates, & Cover Plate option - 6061 anodized aluminum
Linear Rail Material	Stainless Steel
Screw Material	Acme Screw - Stainless Steel
Screw Material	Rolled Ball, Precision Ball, & Ground Ball - Case Hardened Steel
Unidirectional Repeatability	+/- 0.0001 in (2,5 microns) to +/- 0.0002 in (5 microns) - depends on selected screw
Bidirectional Repeatability	+/- 0.0001 in (2,5 microns) to +/- 0.0082 in (208 microns) - depends on selected screw
Straightness	< 0.00013 in/in (< 3,30 microns/25mm)
Flatness	< 0.00013 in/in (< 3,30 microns/25mm)
Orthogonality (multi-axis systems)	< 30 arc-seconds
Friction Coefficient	< 0.01
Motor Mount	NEMA 23 & 34 Mounts, Metric Mounts, Motor Wraps, and Hand Crank Option
Coupling	Three (3) different styles available
Waycover Material (110 series)	Hypilon Polyester Bellows firmly mounted to carriage & end plates

[More Information via the Web](#)

Standard Features

- ❑ Compact 8.0 inches (203 mm) wide by 2.930 inches (74 mm) tall
- ❑ Travel lengths from 6 inches (150 mm) to 60 inches (1520 mm)
- ❑ Threaded stainless steel inserts in carriage for load mounting
- ❑ 0° F to +185° F (-18° C to +85° C) operating temperature
- ❑ 2 rail, 4 bearing, 6 & 12 inch long carriages
- ❑ Recirculating linear ball bearing system
- ❑ Precision ground round rail design

90-WC0 series

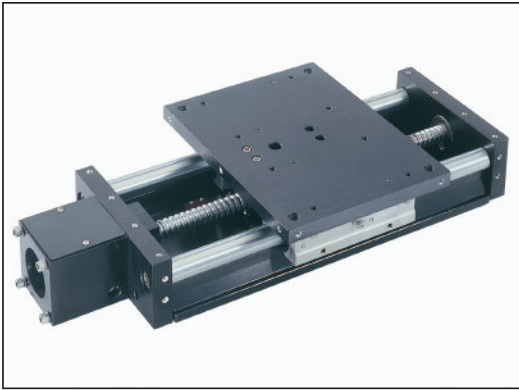

90-WC1 series

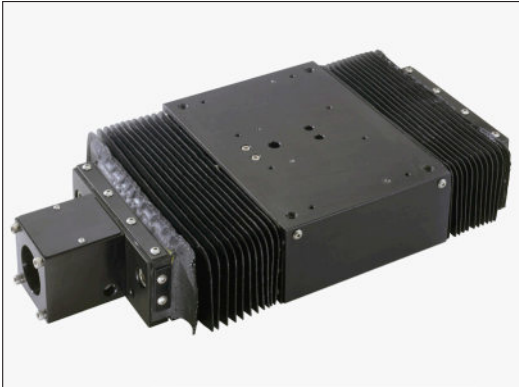

Options

- ❑ Chrome plated linear bearings, rails and screws
- ❑ End of travel (EOT) and home switches wired
- ❑ Adapter brackets for NEMA & Metric motors
- ❑ CAD drawings available via our Website
- ❑ Linear and rotary incremental encoders
- ❑ Power-off electric brakes
- ❑ Vertical angle bracket
- ❑ Motor wrap packages
- ❑ Turcite nut option
- ❑ Motor couplings
- ❑ Hand crank
- ❑ Ball screws:

 Rolled - Non-preloaded & Preloaded Nuts:

0.625 inch diameter, 0.200 inch lead
 0.625 inch diameter, 1.000 inch lead
 0.750 inch diameter, 0.200 inch lead
 0.750 inch diameter, 0.500 inch lead
 1.000 inch diameter, 0.250 inch lead
 1.000 inch diameter, 0.500 inch lead
 1.000 inch diameter, 1.000 inch lead

 Precision - Non-preloaded & Preloaded Nuts:

0.625 inch diameter, 0.200 inch lead
 16 mm diameter, 5 mm lead
 16 mm diameter, 10 mm lead
 16 mm diameter, 16 mm lead
 0.750 inch diameter, 0.200 inch lead
 20 mm diameter, 5 mm lead
 20 mm diameter, 20 mm lead

 Ground - Preloaded Nuts Only:

0.625 inch diameter, 0.200 inch lead
 16 mm diameter, 5 mm lead
 16 mm diameter, 16 mm lead

- ❑ Acme screws:

 Rolled - Non-preloaded & Preloaded Nuts:

0.625 inch diameter, 0.100 inch lead
 0.625 inch diameter, 0.200 inch lead

Specifications

Load Capacities		6 inch (4 bearing) Carriage		12 inch (4 bearing) Carriage	
Dynamic Horizontal ⁽¹⁾	2 million inches (50 km) of travel	3,300 lbs	(1496 kg)	3,300 lbs	(1496 kg)
Dynamic Horizontal ⁽¹⁾	100 million inches (2540 km) of travel	885 lbs	(401 kg)	885 lbs	(401 kg)
Static Horizontal ⁽¹⁾		5,000 lbs	(2268 kg)	5,000 lbs	(2268 kg)
Dynamic Roll Moment ⁽¹⁾	2 million inches (50 km) of travel	380 ft-lbs	(515 N-m)	380 ft-lbs	(515 N-m)
Dynamic Roll Moment ⁽¹⁾	100 million inches (2540 km) of travel	102 ft-lbs	(138 N-m)	102 ft-lbs	(138 N-m)
Static Roll Moment ⁽¹⁾		575 ft-lbs	(780 N-m)	575 ft-lbs	(780 N-m)
Dyn. Pitch & Yaw Moment ⁽¹⁾	2 million inches (50 km) of travel	150 ft-lbs	(203 N-m)	525 ft-lbs	(712 N-m)
Dyn. Pitch & Yaw Moment ⁽¹⁾	100 million inches (2540 km) of travel	41 ft-lbs	(55 N-m)	141 ft-lbs	(191 N-m)
Static Pitch & Yaw Moment ⁽¹⁾		225 ft-lbs	(305 N-m)	790 ft-lbs	(1071 N-m)
Each Bearing Dyn. Cap. ⁽¹⁾	2 million inches (50 km) of travel	825 lbs	(374 kg)	825 lbs	(374 kg)
Each Bearing Dyn. Cap. ⁽¹⁾	100 million inches (2540 km) of travel	222 lbs	(100 kg)	222 lbs	(100 kg)
Each Bearing Static Load Capacity ⁽¹⁾		1,250 lbs	(567 kg)	1,250 lbs	(567 kg)
Thrust Force Capacity	10 million screw revolutions	895 lbs	(406 kg)	895 lbs	(406 kg)
Thrust Force Capacity	500 million screw revolutions	240 lbs	(109 kg)	240 lbs	(109 kg)
Maximum Acceleration		772 in/sec ²	(19,6 m/sec ²)	772 in/sec ²	(19,6 m/sec ²)
d₁	Center to center distance (spread) between the two rails	4.500 in	(114,3 mm)	4.500 in	(114,3 mm)
d₂	Center to center distance (spacing) of the bearings on a single rail	2.500 in	(63,5 mm)	8.620 in	(218,9 mm)
d_r	Center distance of the bearing to top of carriage plate surface	1.437 in	(36,5 mm)	1.437 in	(36,5 mm)

Other	For Six (6) & Twelve (12) Inch Carriages
Table Material	Base, Carriage & End Plates - 6061 anodized aluminum
Linear Rail Material	Case Hardened Steel
Screw Material	Acme Screw - Stainless Steel
Screw Material	Rolled Ball, Precision Ball, & Ground Ball - Case Hardened Steel
Unidirectional Repeatability	+/- 0.0002 in (5 microns)
Bidirectional Repeatability	+/- 0.0002 in (5 microns) to +/- 0.0092 in (234 microns) - depends on selected screw
Straightness	< 0.00016 in/in (< 4,06 microns/25mm)
Flatness	< 0.00016 in/in (< 4,06 microns/25mm)
Orthogonality (multi-axis systems)	< 30 arc-seconds
Friction Coefficient	< 0.01
Motor Mount	NEMA 23 & 34 Mounts, Metric Mounts, Motor Wraps, and Hand Crank Option
Coupling	Three (3) different styles available
Waycover Material	Hypilon Polyester Bellows firmly mounted to carriage & end plates

Footnotes:

(1) Derate value by 50 % when load is applied to the open end of the bearing (such as in moment loads and inverted configurations).

[More Information via the Web](#)

Standard Features

- Compact 5.50 inches (139,7 mm) wide by 2.953 inches (75 mm) tall - 160 series
- Compact 6.00 inches (152,4 mm) wide by 2.953 inches (75 mm) tall - 170 series
- T-slot or threaded stainless steel inserts in carriage for load mounting
- Travel lengths from 6 inches (150 mm) to 60 inches (1520 mm)
- 0° F to +185° F (-18° C to +85° C) operating temperature
- 2 rails, 2 or 4 bearing, 6 inch long carriage
- Recirculating linear ball bearing system
- Precision ground square rail design

160-CP0 series



170-CP0 series

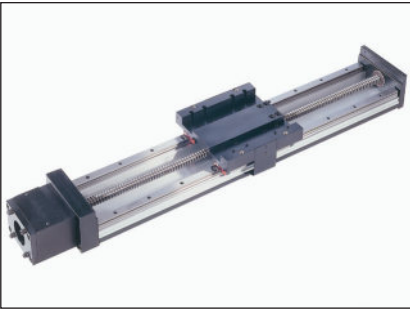

170-CP1 series

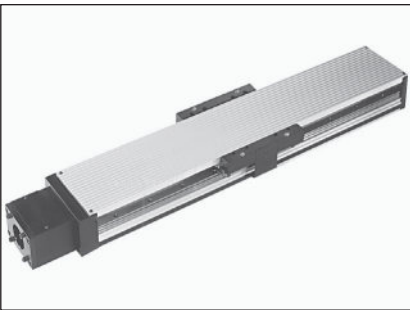

170-CP2 series



Options

- Chrome plated linear bearings, rails and screws
- End of travel (EOT) and home switches wired
- Adapter brackets for NEMA & Metric motors
- CAD drawings available via our Website
- Linear and rotary incremental encoders
- Power-off electric brakes
- Motor wrap packages
- Turcite nut option
- Motor couplings
- Ball screws:

- Cover plates
- Waycovers

Rolled - Non-preloaded & Preloaded Nuts:

- 0.625 inch diameter, 0.200 inch lead
- 0.625 inch diameter, 1.000 inch lead
- 0.750 inch diameter, 0.200 inch lead
- 0.750 inch diameter, 0.500 inch lead

Precision - Non-preloaded & Preloaded Nuts:

- 0.625 inch diameter, 0.200 inch lead
- 16 mm diameter, 5 mm lead
- 16 mm diameter, 10 mm lead
- 16 mm diameter, 16 mm lead
- 0.750 inch diameter, 0.200 inch lead
- 20 mm diameter, 5 mm lead
- 20 mm diameter, 20 mm lead

Ground - Preloaded Nuts Only:

- 0.625 inch diameter, 0.200 inch lead
- 0.625 inch diameter, 0.500 inch lead

- Acme screws:

Rolled - Non-preloaded & Preloaded Nuts:

- 0.625 inch diameter, 0.100 inch lead
- 0.625 inch diameter, 0.200 inch lead

170-WC1 series



Specifications

Load Capacities		Two (2) Bearing Carriage		Four (4) Bearing Carriage	
Dynamic Horizontal	2 million inches (50 km) of travel	3,890 lbs	(1765 kgf)	7,780 lbs	(3530 kgf)
Dynamic Horizontal	100 million inches (2540 km) of travel	1,045 lbs	(474 kgf)	2,090 lbs	(948 kgf)
Static Horizontal		5,820 lbs	(2640 kgf)	11,640 lbs	(5280 kgf)
Dynamic Roll Moment	2 million inches (50 km) of travel	510 ft-lbs	(690 N-m)	1,025 ft-lbs	(1390 N-m)
Dynamic Roll Moment	100 million inches (2540 km) of travel	137 ft-lbs	(185 N-m)	275 ft-lbs	(370 N-m)
Static Roll Moment		915 ft-lbs	(1240 N-m)	1,830 ft-lbs	(2480 N-m)
Dyn. Pitch & Yaw Moment	2 million inches (50 km) of travel	71 ft-lbs	(96 N-m)	930 ft-lbs	(1260 N-m)
Dyn. Pitch & Yaw Moment	100 million inches (2540 km) of travel	19 ft-lbs	(26 N-m)	250 ft-lbs	(339 N-m)
Static Pitch & Yaw Moment		126 ft-lbs	(170 N-m)	1,670 ft-lbs	(2260 N-m)
Each Bearing Dyn. Capacity	2 million inches (50 km) of travel	1,945 lbs	(882 kgf)	1,945 lbs	(882 kgf)
Each Bearing Dyn. Capacity	100 million inches (2540 km) of travel	525 lbs	(238 kgf)	525 lbs	(238 kgf)
Each Bearing Static Load Capacity		2,910 lbs	(1320 kgf)	2,910 lbs	(1320 kgf)
Thrust Force Capacity	10 million screw revolutions	895 lbs	(406 kgf)	895 lbs	(406 kgf)
Thrust Force Capacity	500 million screw revolutions	240 lbs	(109 kgf)	240 lbs	(109 kgf)
Maximum Acceleration		386 in/sec ²	(9,8 m/sec ²)	772 in/sec ²	(19,6 m/sec ²)
d₁	Center to center distance (spread) between the two rails	3.660 in	(92,96 mm)	3.660 in	(92,96 mm)
d₂	Center to center distance (spacing) of the bearings on a single rail		-	3.290 in	(83,57 mm)
d_r	Center distance of the bearing to top of carriage plate surface	1.320 in	(33,53 mm)	1.320 in	(33,53 mm)

Other	For Two (2) & Four (4) Bearing Carriages
Table Material	Base, Carriage, End Plates & Cover Plate Option - 6061 anodized aluminum
Linear Rail Material	Case Hardened Steel
Screw Material	Acme Screw - Stainless Steel
Screw Material	Rolled Ball, Precision Ball, & Ground Ball - Case Hardened Steel
Unidirectional Repeatability	+/- 0.0002 in (5 microns)
Bidirectional Repeatability	+/- 0.0002 in (5 microns) to +/- 0.0082 in (208 microns) - depends on selected screw
Straightness	< 0.00016 in/in (< 4,06 microns/25mm)
Flatness	< 0.00016 in/in (< 4,06 microns/25mm)
Orthogonality (multi-axis systems)	< 30 arc-seconds
Friction Coefficient	< 0.01
Motor Mount	NEMA 23 & 34 Mounts, Metric Mounts, Motor Wraps, and Hand Crank Option
Coupling	Three (3) different styles available
Waycover Material	Hypilon Polyester Bellows mounted to carriage & end plates

[More Information via the Web](#)

Standard Features

- ❑ Compact 6.00 inches (152,4 mm) wide by 2.953 inches (75 mm) tall
- ❑ Threaded stainless steel inserts in carriage for load mounting
- ❑ Travel lengths from 6 inches (150 mm) to 60 inches (1520 mm)
- ❑ 0° F to +185° F (-18° C to +85° C) operating temperature
- ❑ 2 rails, 4 or 6 bearing, 12 inch long carriage
- ❑ Recirculating linear ball bearing system
- ❑ Precision ground square rail design

170-CP0 series

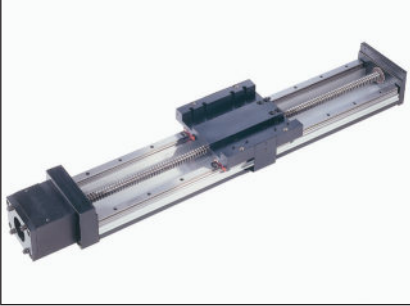

170-CP1 series

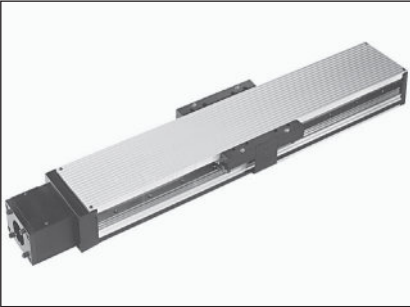

170-CP2 series



170-WC1 series



Options

- ❑ Chrome plated linear bearings, rails and screws
- ❑ End of travel (EOT) and home switches wired
- ❑ Adapter brackets for NEMA & Metric motors
- ❑ CAD drawings available via our Website
- ❑ Linear and rotary incremental encoders
- ❑ Power-off electric brakes
- ❑ Motor wrap packages
- ❑ Turcite nut option
- ❑ Motor couplings
- ❑ Ball screws:

Rolled - Non-preloaded & Preloaded Nuts:

- 0.625 inch diameter, 0.200 inch lead
- 0.625 inch diameter, 1.000 inch lead
- 0.750 inch diameter, 0.200 inch lead
- 0.750 inch diameter, 0.500 inch lead

Precision - Non-preloaded & Preloaded Nuts:

- 0.625 inch diameter, 0.200 inch lead
- 16 mm diameter, 5 mm lead
- 16 mm diameter, 10 mm lead
- 16 mm diameter, 16 mm lead
- 0.750 inch diameter, 0.200 inch lead
- 20 mm diameter, 5 mm lead
- 20 mm diameter, 20 mm lead

Ground - Preloaded Nuts Only:

- 0.625 inch diameter, 0.200 inch lead
- 0.625 inch diameter, 0.500 inch lead

- ❑ Acme screws:

Rolled - Non-preloaded & Preloaded Nuts:

- 0.625 inch diameter, 0.100 inch lead
- 0.625 inch diameter, 0.200 inch lead

Specifications

Load Capacities		Four (4) Bearing Carriage		Six (6) Bearing Carriage	
Dynamic Horizontal	2 million inches (50 km) of travel	7,780 lbs	(3530 kgf)	11,670 lbs	(5290 kgf)
Dynamic Horizontal	100 million inches (2540 km) of travel	2,090 lbs	(948 kgf)	3,135 lbs	(1420 kgf)
Static Horizontal		11,640 lbs	(5280 kgf)	17,460 lbs	(7920 kgf)
Dynamic Roll Moment	2 million inches (50 km) of travel	1,025 ft-lbs	(1390 N-m)	1,540 ft-lbs	(2085 N-m)
Dynamic Roll Moment	100 million inches (2540 km) of travel	275 ft-lbs	(370 N-m)	410 ft-lbs	(555 N-m)
Static Roll Moment		1,830 ft-lbs	(2480 N-m)	2,750 ft-lbs	(3725 N-m)
Dyn. Pitch & Yaw Moment	2 million inches (50 km) of travel	2,160 ft-lbs	(2925 N-m)	2,235 ft-lbs	(3030 N-m)
Dyn. Pitch & Yaw Moment	100 million inches (2540 km) of travel	580 ft-lbs	(785 N-m)	600 ft-lbs	(810 N-m)
Static Pitch & Yaw Moment		3,860 ft-lbs	(5230 N-m)	3,980 ft-lbs	(5395 N-m)
Each Bearing Dyn. Capacity	2 million inches (50 km) of travel	1,945 lbs	(882 kgf)	1,945 lbs	(882 kgf)
Each Bearing Dyn. Capacity	100 million inches (2540 km) of travel	525 lbs	(238 kgf)	525 lbs	(238 kgf)
Each Bearing Static Load Capacity		2,910 lbs	(1320 kgf)	2,910 lbs	(1320 kgf)
Thrust Force Capacity	10 million screw revolutions	895 lbs	(406 kgf)	895 lbs	(406 kgf)
Thrust Force Capacity	500 million screw revolutions	240 lbs	(109 kgf)	240 lbs	(109 kgf)
Maximum Acceleration		772 in/sec ²	(19,6 m/sec ²)	772 in/sec ²	(19,6 m/sec ²)
d₁	Center to center distance (spread) between the two rails	3.660 in	(92,96 mm)	3.660 in	(92,96 mm)
d₂	Center to center distance (spacing) of the bearings on a single rail	9.290 in	(235,97 mm)	4.645 in	(117,98 mm)
d_r	Center distance of the bearing to top of carriage plate surface	1.320 in	(33,53 mm)	1.320 in	(33,53 mm)

Other	For Four (4) & Six (6) Bearing Carriages
Table Material	Base, Carriage, End Plates & Cover Plate Option - 6061 anodized aluminum
Linear Rail Material	Case Hardened Steel
Screw Material	Acme Screw - Stainless Steel
Screw Material	Rolled Ball, Precision Ball, & Ground Ball - Case Hardened Steel
Unidirectional Repeatability	+/- 0.0002 in (5 microns)
Bidirectional Repeatability	+/- 0.0002 in (5 microns) to +/- 0.0082 in (208 microns) - depends on selected screw
Straightness	< 0.00016 in/in (< 4,06 microns/25mm)
Flatness	< 0.00016 in/in (< 4,06 microns/25mm)
Orthogonality (multi-axis systems)	< 30 arc-seconds
Friction Coefficient	< 0.01
Motor Mount	NEMA 23 & 34 Mounts, Metric Mounts, Motor Wraps, and Hand Crank Option
Coupling	Three (3) different styles available
Waycover Material	Hypilon Polyester Bellows mounted to carriage & end plates

[More Information via the Web](#)

Standard Features

- ❑ Compact 5.91 inches (150 mm) wide by 2.953 inches (75 mm) tall
- ❑ Travel lengths from 6 inches (150 mm) to 60 inches (1520 mm)
- ❑ Threaded stainless steel inserts in carriage for load mounting
- ❑ 0° F to +185° F (-18° C to +85° C) operating temperature
- ❑ 2 rails, 4 self lube bearings and 6 inch long carriage
- ❑ Precision ground profilr linear rail design
- ❑ Recirculating linear ball bearing system
- ❑ IP30 rated enclosed positioning slide

610 series

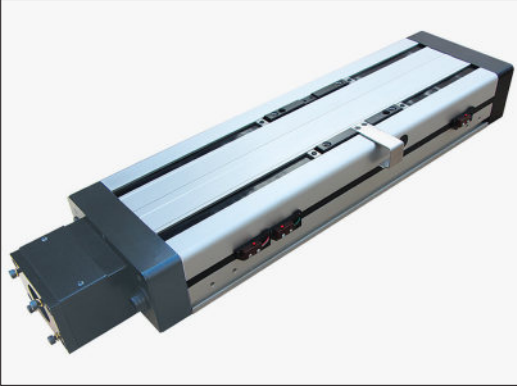

Options

- ❑ Chrome plated linear bearings, rails and screws
- ❑ End of travel (EOT) and home switches wired
- ❑ Adapter brackets for NEMA & Metric motors
- ❑ CAD drawings available via our Website
- ❑ Rotary incremental encoders
- ❑ Power-off electric brakes
- ❑ Motor wrap packages
- ❑ Turcite nut option
- ❑ Motor Couplings
- ❑ Ball screws:

Rolled - Non-preloaded & Preloaded Nuts:

- 0.625 inch diameter, 0.200 inch lead
- 0.625 inch diameter, 1.000 inch lead
- 0.750 inch diameter, 0.200 inch lead
- 0.750 inch diameter, 0.500 inch lead

Precision - Non-preloaded & Preloaded Nuts:

- 0.625 inch diameter, 0.200 inch lead
- 16 mm diameter, 5 mm lead
- 16 mm diameter, 10 mm lead
- 16 mm diameter, 16 mm lead
- 0.750 inch diameter, 0.200 inch lead
- 20 mm diameter, 5 mm lead
- 20 mm diameter, 20 mm lead

Ground - Preloaded Nuts Only:

- 0.625 inch diameter, 0.200 inch lead
- 0.625 inch diameter, 0.500 inch lead

- ❑ Acme screws:

Rolled - Non-preloaded & Preloaded Nuts:

- 0.625 inch diameter, 0.100 inch lead
- 0.625 inch diameter, 0.200 inch lead

Specifications

Load Capacities		Four (4) Bearing Carriage	
Dynamic Horizontal	2 million inches (50 km) of travel	7,780 lbs	(3530 kgf)
Dynamic Horizontal	100 million inches (2540 km) of travel	2,090 lbs	(948 kgf)
Static Horizontal		11,640 lbs	(5280 kgf)
Dynamic Roll Moment	2 million inches (50 km) of travel	920 ft-lbs	(1247 N-m)
Dynamic Roll Moment	100 million inches (2540 km) of travel	247 ft-lbs	(335 N-m)
Static Roll Moment		1,680 ft-lbs	(2277 N-m)
Dyn. Pitch & Yaw Moment	2 million inches (50 km) of travel	980 ft-lbs	(1328 N-m)
Dyn. Pitch & Yaw Moment	100 million inches (2540 km) of travel	263 ft-lbs	(356 N-m)
Static Pitch & Yaw Moment		1,770 ft-lbs	(2400 N-m)
Each Bearing Dyn. Capacity	2 million inches (50 km) of travel	1,945 lbs	(882 kgf)
Each Bearing Dyn. Capacity	100 million inches (2540 km) of travel	525 lbs	(238 kgf)
Each Bearing Static Load Capacity		2,910 lbs	(1320 kgf)
Thrust Force Capacity	10 million screw revolutions	895 lbs	(406 kgf)
Thrust Force Capacity	500 million screw revolutions	240 lbs	(109 kgf)
Maximum Acceleration		772 in/sec ²	(19,6 m/sec ²)
d₁	Center to center distance (spread) between the two rails	3.228 in	(81,99 mm)
d₂	Center to center distance (spacing) of the bearings on a single rail	3.476 in	(88,29 mm)
d_r	Center distance of the bearing to top of carriage plate surface	1.299 in	(32,99 mm)

Other	Four (4) Bearing Carriages
Table Material	Base, Carriage, End Plates & Cover Plate Option - 6061 anodized aluminum
Linear Rail Material	Case Hardened Steel
Screw Material	Acme Screw - Stainless Steel
Screw Material	Rolled Ball, Precision Ball, & Ground Ball - Case Hardened Steel
Unidirectional Repeatability	+/- 0.0002 in (5 microns)
Bidirectional Repeatability	+/- 0.0002 in (5 microns) to +/- 0.0082 in (208 microns) - depends on selected screw
Straightness	< 0.00016 in/in (< 4,06 microns/25mm)
Flatness	< 0.00016 in/in (< 4,06 microns/25mm)
Orthogonality (multi-axis systems)	< 30 arc-seconds
Friction Coefficient	< 0.01
Motor Mount	NEMA 23 & 34 Mounts, Metric Mounts, Motor Wraps, and Hand Crank Option
Coupling	Three (3) different styles available
Belt Cover Strip Material	Black - Polyurethane

[More Information via the Web](#)

Standard Features

- ❑ Compact 6.750 inches (171 mm) wide by 2.625 inches (67 mm) tall
- ❑ Travel lengths from 6 inches (150 mm) to 62 inches (1570 mm)
- ❑ Threaded stainless steel inserts in carriage for load mounting
- ❑ 0° F to +185° F (-18° C to +85° C) operating temperature
- ❑ 2 rail, 2 & 4 bearing, 4 & 8 inch long carriages
- ❑ Recirculating linear ball bearing system
- ❑ Precision ground square rail design

150-WC0 series



150-WC1 series



Options

- ❑ Chrome plated linear bearings, rails and screws
- ❑ End of travel (EOT) and home switches wired
- ❑ Adapter brackets for NEMA & Metric motors
- ❑ CAD drawings available via our Website
- ❑ Linear and rotary incremental encoders
- ❑ Power-off electric brakes
- ❑ Vertical angle bracket
- ❑ Motor wrap packages
- ❑ Turcite nut option
- ❑ Motor couplings
- ❑ Hand crank
- ❑ Waycovers
- ❑ Ball screws:

 Rolled - Non-preloaded & Preloaded Nuts:

- 0.625 inch diameter, 0.200 inch lead
- 0.625 inch diameter, 1.000 inch lead
- 0.750 inch diameter, 0.200 inch lead
- 0.750 inch diameter, 0.500 inch lead

 Precision - Non-preloaded & Preloaded Nuts:

- 0.625 inch diameter, 0.200 inch lead
- 16 mm diameter, 5 mm lead
- 16 mm diameter, 10 mm lead
- 16 mm diameter, 16 mm lead
- 0.750 inch diameter, 0.200 inch lead
- 20 mm diameter, 5 mm lead
- 20 mm diameter, 20 mm lead

 Ground - Preloaded Nuts Only:

- 0.625 inch diameter, 0.200 inch lead
- 16 mm diameter, 5 mm lead
- 16 mm diameter, 16 mm lead
- 0.750 inch diameter, 0.200 inch lead
- 0.750 inch diameter, 0.500 inch lead

- ❑ Acme screws:

 Rolled - Non-preloaded & Preloaded Nuts:

- 0.625 inch diameter, 0.100 inch lead
- 0.625 inch diameter, 0.200 inch lead

Specifications

Load Capacities		4 inch (2 bearing) Carriage		8 inch (4 bearing) Carriage	
Dynamic Horizontal	2 million inches (50 km) of travel	1,900 lbs	(862 kg)	3,800 lbs	(1724 kg)
Dynamic Horizontal	100 million inches (2540 km) of travel	510 lbs	(231 kg)	1,020 lbs	(463 kg)
Static Horizontal		3,400 lbs	(1542 kg)	6,800 lbs	(3084 kg)
Dynamic Roll Moment	2 million inches (50 km) of travel	285 ft-lbs	(386 N-m)	575 ft-lbs	(780 N-m)
Dynamic Roll Moment	100 million inches (2540 km) of travel	77 ft-lbs	(104 N-m)	155 ft-lbs	(210 N-m)
Static Roll Moment		515 ft-lbs	(698 N-m)	1,030 ft-lbs	(1396 N-m)
Dyn. Pitch & Yaw Moment	2 million inches (50 km) of travel	56 ft-lbs	(76 N-m)	700 ft-lbs	(949 N-m)
Dyn. Pitch & Yaw Moment	100 million inches (2540 km) of travel	15 ft-lbs	(20 N-m)	190 ft-lbs	(258 N-m)
Static Pitch & Yaw Moment		100 ft-lbs	(136 N-m)	1,255 ft-lbs	(1702 N-m)
Each Bearing Dyn. Capacity	2 million inches (50 km) of travel	950 lbs	(431 kg)	950 lbs	(431 kg)
Each Bearing Dyn. Capacity	100 million inches (2540 km) of travel	255 lbs	(115 kg)	255 lbs	(115 kg)
Each Bearing Static Load Capacity		1,700 lbs	(771 kg)	1,700 lbs	(771 kg)
Thrust Force Capacity	10 million screw revolutions	895 lbs	(406 kg)	895 lbs	(406 kg)
Thrust Force Capacity	500 million screw revolutions	240 lbs	(109 kg)	240 lbs	(109 kg)
Maximum Acceleration		386 in/sec ²	(9,8 m/sec ²)	772 in/sec ²	(19,6 m/sec ²)
d₁	Center to center distance (spread) between the two rails	4.300 in	(109,2 mm)	4.300 in	(109,2 mm)
d₂	Center to center distance (spacing) of the bearings on a single rail		-	4.900 in	(124,5 mm)
d_r	Center distance of the bearing to top of carriage plate surface	1.250 in	(31,8 mm)	1.250 in	(31,8 mm)

Other	For 4 inch (2 bearing) & 8 inch (4 bearing) Carriages
Table Material	Base, Carriage, & End Plates - 6061 anodized aluminum
Linear Rail Material	Case Hardened Steel
Screw Material	Acme Screw - Stainless Steel
Screw Material	Rolled Ball, Precision Ball, & Ground Ball - Case Hardened Steel
Unidirectional Repeatability	+/- 0.0001 in (2,5 microns) to +/- 0.0002 in (5 microns) - depends on selected screw
Bidirectional Repeatability	+/- 0.0001 in (2,5 microns) to +/- 0.0082 in (208 microns) - depends on selected screw
Straightness	< 0.00004 in/in (< 1,02 microns/25mm)
Flatness	< 0.00004 in/in (< 1,02 microns/25mm)
Orthogonality (multi-axis systems)	< 15 arc-seconds
Friction Coefficient	< 0.01
Motor Mount	NEMA 23 & 34 Mounts, Metric Mounts, Motor Wraps, and Hand Crank Option
Coupling	Three (3) different styles available
Waycover Material	Hypilon Polyester Bellows firmly mounted to carriage & end plates

[More Information via the Web](#)

Standard Features

- ❑ Compact 8.500 inches (216 mm) wide by 3.750 inches (95 mm) tall
- ❑ Travel lengths from 6 inches (150 mm) to 55 inches (1395 mm)
- ❑ Threaded stainless steel inserts in carriage for load mounting
- ❑ 0° F to +185° F (-18° C to +85° C) operating temperature
- ❑ 2 rail, 2 & 4 bearing, 6 & 12 inch long carriages
- ❑ Recirculating linear ball bearing system
- ❑ Precision ground square rail design

200-WC0 series



200-WC1 series



Options

- ❑ Chrome plated linear bearings, rails and screws
- ❑ End of travel (EOT) and home switches wired
- ❑ Adapter brackets for NEMA & Metric motors
- ❑ CAD drawings available via our Website
- ❑ Linear and rotary incremental encoders
- ❑ Power-off electric brakes
- ❑ Vertical angle bracket
- ❑ Motor wrap packages
- ❑ Turcite nut option
- ❑ Motor couplings
- ❑ Hand crank
- ❑ Waycovers
- ❑ Ball screws:

 Rolled - Non-preloaded & Preloaded Nuts:

0.750 inch diameter, 0.200 inch lead
 0.750 inch diameter, 0.500 inch lead

 Precision - Non-preloaded & Preloaded Nuts:

0.750 inch diameter, 0.200 inch lead
 20 mm diameter, 5 mm lead
 20 mm diameter, 20 mm lead

 Ground - Preloaded Nuts Only:

0.750 inch diameter, 0.200 inch lead
 20 mm diameter, 5 mm lead
 20 mm diameter, 20 mm lead

- ❑ Acme screws:

 Rolled - Non-preloaded & Preloaded Nuts:

0.750 inch diameter, 0.100 inch lead
 0.750 inch diameter, 0.200 inch lead

Specifications

Load Capacities		6 inch (2 bearing) Carriage		12 inch (4 bearing) Carriage	
Dynamic Horizontal	2 million inches (50 km) of travel	4,400 lbs	(1996 kg)	8,800 lbs	(3992 kg)
Dynamic Horizontal	100 million inches (2540 km) of travel	1,180 lbs	(535 kg)	2,360 lbs	(1070 kg)
Static Horizontal		7,600 lbs	(3447 kg)	15,200 lbs	(6895 kg)
Dynamic Roll Moment	2 million inches (50 km) of travel	790 ft-lbs	(1071 N-m)	1,580 ft-lbs	(2142 N-m)
Dynamic Roll Moment	100 million inches (2540 km) of travel	210 ft-lbs	(285 N-m)	425 ft-lbs	(576 N-m)
Static Roll Moment		1,365 ft-lbs	(1851 N-m)	2,730 ft-lbs	(3701 N-m)
Dyn. Pitch & Yaw Moment	2 million inches (50 km) of travel	175 ft-lbs	(237 N-m)	2,485 ft-lbs	(3369 N-m)
Dyn. Pitch & Yaw Moment	100 million inches (2540 km) of travel	47 ft-lbs	(64 N-m)	670 ft-lbs	(908 N-m)
Static Pitch & Yaw Moment		300 ft-lbs	(407 N-m)	4,300 ft-lbs	(5830 N-m)
Each Bearing Dyn. Capacity	2 million inches (50 km) of travel	2,200 lbs	(998 kg)	2,200 lbs	(998 kg)
Each Bearing Dyn. Capacity	100 million inches (2540 km) of travel	590 lbs	(265 kg)	590 lbs	(265 kg)
Each Bearing Static Load Capacity		3,800 lbs	(1724 kg)	3,800 lbs	(1724 kg)
Thrust Force Capacity	10 million screw revolutions	1,050 lbs	(476 kg)	1,050 lbs	(476 kg)
Thrust Force Capacity	500 million screw revolutions	270 lbs	(122 kg)	270 lbs	(122 kg)
Maximum Acceleration		386 in/sec ²	(9,8 m/sec ²)	772 in/sec ²	(19,6 m/sec ²)
d₁	Center to center distance (spread) between the two rails	5.280 in	(134,1 mm)	5.280 in	(134,1 mm)
d₂	Center to center distance (spacing) of the bearings on a single rail		-	7.870 in	(199,9 mm)
d_r	Center distance of the bearing to top of carriage plate surface	1.900 in	(48,3 mm)	1.900 in	(48,3 mm)

Other	For 6 inch (2 bearing) & 12 inch (4 bearing) Carriages
Table Material	Base, Carriage, & End Plates - 6061 anodized aluminum
Linear Rail Material	Case Hardened Steel
Screw Material	Acme Screw - Stainless Steel
Screw Material	Rolled Ball, Precision Ball, & Ground Ball - Case Hardened Steel
Unidirectional Repeatability	+/- 0.0001 in (2,5 microns) to +/- 0.0002 in (5 microns) - depends on selected screw
Bidirectional Repeatability	+/- 0.0001 in (2,5 microns) to +/- 0.0082 in (208 microns) - depends on selected screw
Straightness	< 0.00004 in/in (< 1,02 microns/25mm)
Flatness	< 0.00004 in/in (< 1,02 microns/25mm)
Orthogonality (multi-axis systems)	< 15 arc-seconds
Friction Coefficient	< 0.01
Motor Mount	NEMA 23 & 34 Mounts, Metric Mounts, Motor Wraps, and Hand Crank Option
Coupling	Three (3) different styles available
Waycover Material	Hypilon Polyester Bellows firmly mounted to carriage & end plates

[More Information via the Web](#)

Standard Features

- ❑ Compact 10.0 inches (254 mm) wide by 4.875 inches (124 mm) tall
- ❑ Travel lengths from 6 inches (150 mm) to 56 inches (1420 mm)
- ❑ Threaded stainless steel inserts in carriage for load mounting
- ❑ 0° F to +185° F (-18° C to +85° C) operating temperature
- ❑ 2 rail, 2 & 4 bearing, 6 & 12 inch long carriages
- ❑ Recirculating linear ball bearing system
- ❑ Precision ground square rail design

250-WC0 series



250-WC1 series



Options

- ❑ Chrome plated linear bearings, rails and screws
- ❑ End of travel (EOT) and home switches wired
- ❑ Adapter brackets for NEMA & Metric motors
- ❑ CAD drawings available via our Website
- ❑ Linear and rotary incremental encoders
- ❑ Power-off electric brakes
- ❑ Vertical angle bracket
- ❑ Motor wrap packages
- ❑ Turcite nut option
- ❑ Motor couplings
- ❑ Waycovers

❑ Ball screws:

Rolled - Non-preloaded & Preloaded Nuts:

- 1.000 inch diameter, 0.250 inch lead
- 1.000 inch diameter, 0.500 inch lead
- 1.000 inch diameter, 1.000 inch lead

Precision - Non-preloaded & Preloaded Nuts:

- 1.000 inch diameter, 0.200 inch lead
- 25 mm diameter, 10 mm lead
- 25 mm diameter, 25 mm lead

Ground - Preloaded Nuts Only:

- 1.000 inch diameter, 0.200 inch lead
- 1.000 inch diameter, 0.500 inch lead
- 25 mm diameter, 25 mm lead

❑ Acme screws:

Rolled - Non-preloaded & Preloaded Nuts:

- 1.000 inch diameter, 0.100 inch lead
- 1.000 inch diameter, 0.200 inch lead

Specifications

Load Capacities		6 inch (2 bearing) Carriage		12 inch (4 bearing) Carriage	
Dynamic Horizontal	2 million inches (50 km) of travel	8,300 lbs	(3765 kg)	16,600 lbs	(7530 kg)
Dynamic Horizontal	100 million inches (2540 km) of travel	2,225 lbs	(1009 kg)	4,455 lbs	(2020 kg)
Static Horizontal		13,600 lbs	(6169 kg)	27,200 lbs	(12338 kg)
Dynamic Roll Moment	2 million inches (50 km) of travel	1,655 ft-lbs	(2244 N-m)	3,310 ft-lbs	(4488 N-m)
Dynamic Roll Moment	100 million inches (2540 km) of travel	445 ft-lbs	(603 N-m)	895 ft-lbs	(1213 N-m)
Static Roll Moment		2,715 ft-lbs	(3681 N-m)	5,425 ft-lbs	(7355 N-m)
Dyn. Pitch & Yaw Moment	2 million inches (50 km) of travel	455 ft-lbs	(617 N-m)	3,930 ft-lbs	(5328 N-m)
Dyn. Pitch & Yaw Moment	100 million inches (2540 km) of travel	121 ft-lbs	(164 N-m)	1,065 ft-lbs	(1444 N-m)
Static Pitch & Yaw Moment		635 ft-lbs	(861 N-m)	6,450 ft-lbs	(8745 N-m)
Each Bearing Dyn. Capacity	2 million inches (50 km) of travel	4,150 lbs	(1882 kg)	4,150 lbs	(1882 kg)
Each Bearing Dyn. Capacity	100 million inches (2540 km) of travel	1,115 lbs	(505 kg)	1,115 lbs	(505 kg)
Each Bearing Static Load Capacity		6,800 lbs	(3084 kg)	6,800 lbs	(3084 kg)
Thrust Force Capacity	10 million screw revolutions	1,685 lbs	(764 kg)	1,685 lbs	(764 kg)
Thrust Force Capacity	500 million screw revolutions	455 lbs	(206 kg)	455 lbs	(206 kg)
Maximum Acceleration		386 in/sec ²	(9,8 m/sec ²)	772 in/sec ²	(19,6 m/sec ²)
d₁	Center to center distance (spread) between the two rails	6.000 in	(152,4 mm)	6.000 in	(152,4 mm)
d₂	Center to center distance (spacing) of the bearings on a single rail		-	6.730 in	(170,9 mm)
d_r	Center distance of the bearing to top of carriage plate surface	2.180 in	(55,4 mm)	2.180 in	(55,4 mm)

Other	For 6 inch (2 bearing) & 12 inch (4 bearing) Carriages
Table Material	Base, Carriage, & End Plates - 6061 anodized aluminum
Linear Rail Material	Case Hardened Steel
Screw Material	Acme Screw - Stainless Steel
Screw Material	Rolled Ball, Precision Ball, & Ground Ball - Case Hardened Steel
Unidirectional Repeatability	+/- 0.0001 in (2,5 microns) to +/- 0.0002 in (5 microns) - depends on selected screw
Bidirectional Repeatability	+/- 0.0001 in (2,5 microns) to +/- 0.0092 in (234 microns) - depends on selected screw
Straightness	< 0.00004 in/in (< 1,02 microns/25mm)
Flatness	< 0.00004 in/in (< 1,02 microns/25mm)
Orthogonality (multi-axis systems)	< 15 arc-seconds
Friction Coefficient	< 0.01
Motor Mount	NEMA 34 & 42 Mounts, Metric Mounts, Motor Wraps, and Hand Crank Option
Coupling	Three (3) different styles available
Waycover Material	Hypilon Polyester Bellows firmly mounted to carriage & end plates

[More Information via the Web](#)

Standard Features

- ❑ Compact 2.875 inches (73 mm) wide by 3.000 inches (76 mm) tall
- ❑ Travel lengths from 4 inches (100 mm) to 10 feet (3,0 meters)
- ❑ Threaded stainless steel inserts in carriage for load mounting
- ❑ Polyurethane belt with high strength steel tension members
- ❑ 0° F to +176° F (-18° C to +80° C) operating temperature
- ❑ Single screw belt tensioning with self locking thread
- ❑ Dynamic Load Capacity to 200 lbs (90 kg)
- ❑ Recirculating linear ball bearing system
- ❑ Precision ground square rail design
- ❑ 1 rail, 1 or 2 bearing carriages

140-CP0 series



Options

- ❑ End of travel (EOT) and home switches wired
- ❑ Adapter brackets for NEMA & Metric motors
- ❑ CAD drawings available via our Website
- ❑ Chrome plated linear bearings & rails
- ❑ Rotary incremental encoders
- ❑ NEMA 34 adapter bracket
- ❑ Power-off electric brakes
- ❑ Carriage adapter plates
- ❑ Vertical angle bracket
- ❑ Motor couplings

140-CP1 series

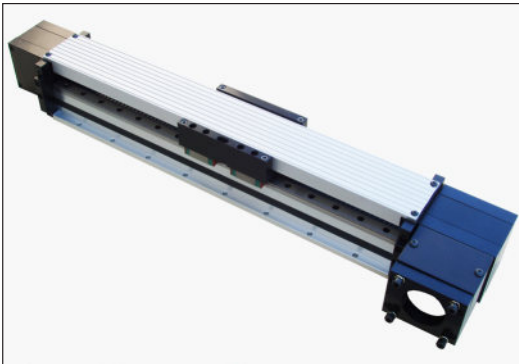

140-CP2 series



Specifications

Load Capacities		One (1) Bearing Carriage	Two (2) Bearing Carriage
Dynamic Horizontal	2 million inches (50 km) of travel	100 lbs (45 kg)	200 lbs (90 kg)
Dynamic Horizontal	100 million inches (2540 km) of travel	27 lbs (12 kg)	54 lbs (24 kg)
Static Horizontal		200 lbs (90 kg)	400 lbs (180 kg)
Dynamic Roll Moment	2 million inches (50 km) of travel	8 ft-lbs (11 N-m)	16 ft-lbs (22 N-m)
Dynamic Roll Moment	100 million inches (2540 km) of travel	2 ft-lbs (3 N-m)	4 ft-lbs (6 N-m)
Static Roll Moment		14 ft-lbs (19 N-m)	28 ft-lbs (38 N-m)
Dyn. Pitch & Yaw Moment	2 million inches (50 km) of travel	4 ft-lbs (5,4 N-m)	15 ft-lbs (20 N-m)
Dyn. Pitch & Yaw Moment	100 million inches (2540 km) of travel	1 ft-lbs (1,9 N-m)	4 ft-lbs (6 N-m)
Static Pitch & Yaw Moment		8 ft-lbs (10 N-m)	30 ft-lbs (40 N-m)
Each Bearing Dyn. Capacity	2 million inches (50 km) of travel	100 lbs (45 kg)	100 lbs (45 kg)
Each Bearing Dyn. Capacity	100 million inches (2540 km) of travel	27 lbs (12 kg)	27 lbs (12 kg)
Each Bearing Static Load Capacity		200 lbs (90 kg)	200 lbs (90 kg)
Maximum Belt Tensile Force		250 lbs (113 kg)	250 lbs (113 kg)
Maximum Carriage Thrust Force		115 lbs (52 kg)	115 lbs (52 kg)
Maximum Speed		78 in/sec (2 m/sec)	78 in/sec (2 m/sec)
Maximum Acceleration		193 in/sec ² (4,9 m/sec ²)	386 in/sec ² (9,8 m/sec ²)
d₂	Center to center distance (spacing) of each bearing on a single rail	-	2.088 in (53,0 mm)
d_r	Center distance of the bearing to top of carriage plate surface	1.375 in (34,9 mm)	1.375 in (34,9 mm)

Other	For One (1) & Two (2) Bearing Carriages
Table Material	Base, Carriage, End Plates, & Cover Plate - 6061 anodized aluminum
Linear Rail Material	Stainless Steel
Belt Properties	Black, 16 mm wide, Polyurethane, Steel reinforced belt
Drive Pulley Weight	0.21 lbs (0,10 kg)
Drive Pulley Diameter	1.128 in (28,65 mm)
Drive Lead	3.543 in (90,00 mm)
Belt Stretch - x Load (lbs or N)	0.00025 in/ft per lbs (0,00476 mm/m per N)
Unidirectional Repeatability	+/- 0.001 in (+/- 0,0254 mm)
Bidirectional Repeatability	+/- 0.004 in (+/- 0,1016 mm)
Position Accuracy (Belt)	< 0.010 in/ft (< 0,254 mm/300mm)
Orthogonality (multi-axis systems)	< 30 arc-seconds
Friction Coefficient	< 0.01
Breakaway Torque	< 40 oz-in (0,282 N-m)
Motor Mount	NEMA 23 & 34 Mounts, Metric Mounts, and Gearheads
Coupling	Two (2) different styles available

[More Information via the Web](#)

Standard Features

- ❑ Compact 3.500 inches (89 mm) wide by 3.000 inches (76 mm) tall
- ❑ Travel lengths from 4 inches (100 mm) to 10 feet (3,0 meters)
- ❑ Threaded stainless steel inserts in carriage for load mounting
- ❑ Polyurethane belt with high strength steel tension members
- ❑ 0° F to +176° F (-18° C to +80° C) operating temperature
- ❑ Single screw belt tensioning with self locking thread
- ❑ Dynamic Load Capacity to 3,100 lbs (1406 kg)
- ❑ Recirculating linear ball bearing system
- ❑ Precision ground square rail design
- ❑ 2 rails, 2 or 4 bearing carriages

120-CP0 series

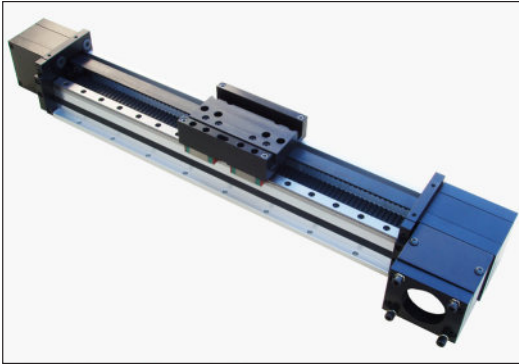

Options

- ❑ End of travel (EOT) and home switches wired
- ❑ Adapter brackets for NEMA & Metric motors
- ❑ CAD drawings available via our Website
- ❑ Chrome plated linear bearings & rails
- ❑ Rotary incremental encoders
- ❑ NEMA 34 adapter bracket
- ❑ Power-off electric brakes
- ❑ Carriage adapter plates
- ❑ Vertical angle bracket
- ❑ Motor couplings

120-CP1 series

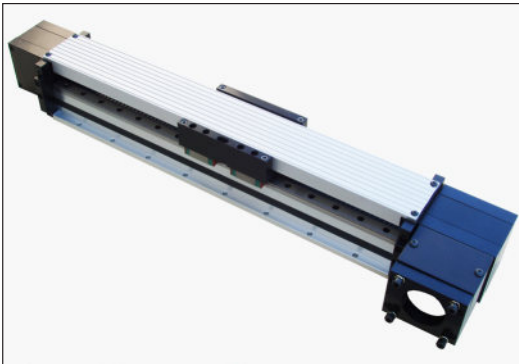

120-CP2 series



Specifications

Load Capacities		Two (2) Bearing Carriage		Four (4) Bearing Carriage	
Dynamic Horizontal	2 million inches (50 km) of travel	1,550 lbs	(703 kg)	3,100 lbs	(1406 kg)
Dynamic Horizontal	100 million inches (2540 km) of travel	415 lbs	(188 kg)	840 lbs	(381 kg)
Static Horizontal		2,360 lbs	(1070 kg)	4,720 lbs	(2140 kg)
Dynamic Roll Moment	2 million inches (50 km) of travel	140 ft-lbs	(190 N-m)	280 ft-lbs	(379 N-m)
Dynamic Roll Moment	100 million inches (2540 km) of travel	37 ft-lbs	(50 N-m)	75 ft-lbs	(101 N-m)
Static Roll Moment		210 ft-lbs	(285 N-m)	425 ft-lbs	(576 N-m)
Dyn. Pitch & Yaw Moment	2 million inches (50 km) of travel	18 ft-lbs	(24 N-m)	240 ft-lbs	(325 N-m)
Dyn. Pitch & Yaw Moment	100 million inches (2540 km) of travel	5 ft-lbs	(7 N-m)	65 ft-lbs	(88 N-m)
Static Pitch & Yaw Moment		30 ft-lbs	(41 N-m)	365 ft-lbs	(495 N-m)
Each Bearing Dyn. Capacity	2 million inches (50 km) of travel	775 lbs	(351 kg)	775 lbs	(351 kg)
Each Bearing Dyn. Capacity	100 million inches (2540 km) of travel	208 lbs	(94 kg)	208 lbs	(94 kg)
Each Bearing Static Load Capacity		1,180 lbs	(535 kg)	1,180 lbs	(535 kg)
Maximum Belt Tensile Force		250 lbs	(113 kg)	250 lbs	(113 kg)
Maximum Carriage Thrust Force		115 lbs	(52 kg)	115 lbs	(52 kg)
Maximum Speed		118 in/sec	(3 m/sec)	118 in/sec	(3 m/sec)
Maximum Acceleration		386 in/sec ²	(9,8 m/sec ²)	772 in/sec ²	(19,6 m/sec ²)
d₁	Center to center distance (spread) between the two rails	2.375 in	(60,3 mm)	2.375 in	(60,3 mm)
d₂	Center to center distance (spacing) of the bearings on a single rail		-	2.088 in	(53,0 mm)
d_r	Center distance of the bearing to top of carriage plate surface	1.375 in	(34,9 mm)	1.375 in	(34,9 mm)

Other	For Two (2) & Four (4) Bearing Carriages
Table Material	Base, Carriage, End Plates, & Cover Plate - 6061 anodized aluminum
Linear Rail Material	Stainless Steel
Belt Properties	Black, 16 mm wide, Polyurethane, Steel reinforced belt
Drive Pulley Weight	0.21 lbs (0,10 kg)
Drive Pulley Diameter	1.128 in (28,65 mm)
Drive Lead	3.543 in (90,00 mm)
Belt Stretch - x Load (lbs or N)	0.00025 in/ft per lbs (0,00476 mm/m per N)
Unidirectional Repeatability	+/- 0.001 in (+/- 0,0254 mm)
Bidirectional Repeatability	+/- 0.004 in (+/- 0,1016 mm)
Position Accuracy (Belt)	< 0.010 in/ft (< 0,254 mm/300mm)
Orthogonality (multi-axis systems)	< 30 arc-seconds
Friction Coefficient	< 0.01
Breakaway Torque	< 60 oz-in (0,424 N-m)
Motor Mount	NEMA 23 & 34 Mounts, Metric Mounts, and Gearheads
Coupling	Two (2) different styles available

[More Information via the Web](#)

Standard Features

- ❑ Compact 6.0 inches (152 mm) wide by 2.953 inches (75 mm) tall
- ❑ Travel lengths from 6 inches (150 mm) to 108 inches (2740 meters)
- ❑ Threaded stainless steel inserts in carriage for load mounting
- ❑ Polyurethane belt with high strength steel tension members
- ❑ 0° F to +176° F (-18° C to +80° C) operating temperature
- ❑ Single screw belt tensioning with self locking thread
- ❑ Dynamic Load Capacity to 5,600 lbs (2540 kg)
- ❑ 2 rails, 2 or 4 bearing, 6 inch long carriage
- ❑ Recirculating linear ball bearing system
- ❑ Precision ground square rail design

180-CP0 series



180-CP1 series



180-CP2 series



Options

- ❑ End of travel (EOT) and home switches wired
- ❑ Adapter brackets for NEMA & Metric motors
- ❑ CAD drawings available via our Website
- ❑ Chrome plated linear bearings & rails
- ❑ Rotary incremental encoders
- ❑ NEMA 34 adapter bracket
- ❑ Power-off electric brakes
- ❑ Carriage adapter plates
- ❑ Planetary gearheads
- ❑ Motor couplings

180-WC1 series

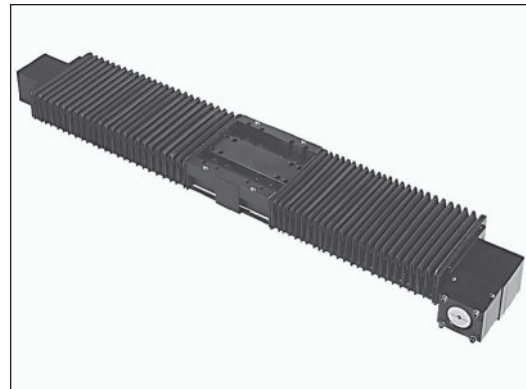

Specifications

Load Capacities		Two (2) Bearing Carriage		Four (4) Bearing Carriage	
Dynamic Horizontal	2 million inches (50 km) of travel	3,890 lbs	(1765 kg)	7,780 lbs	(3530 kg)
Dynamic Horizontal	100 million inches (2540 km) of travel	1,045 lbs	(474 kg)	2,090 lbs	(948 kg)
Static Horizontal		5,820 lbs	(2640 kg)	11,640 lbs	(5280 kg)
Dynamic Roll Moment	2 million inches (50 km) of travel	510 ft-lbs	(690 N-m)	1,025 ft-lbs	(1390 N-m)
Dynamic Roll Moment	100 million inches (2540 km) of travel	137 ft-lbs	(185 N-m)	275 ft-lbs	(370 N-m)
Static Roll Moment		915 ft-lbs	(1240 N-m)	1,830 ft-lbs	(2480 N-m)
Dyn. Pitch & Yaw Moment	2 million inches (50 km) of travel	71 ft-lbs	(96 N-m)	930 ft-lbs	(1260 N-m)
Dyn. Pitch & Yaw Moment	100 million inches (2540 km) of travel	19 ft-lbs	(26 N-m)	250 ft-lbs	(339 N-m)
Static Pitch & Yaw Moment		126 ft-lbs	(170 N-m)	1,670 ft-lbs	(2260 N-m)
Each Bearing Dyn. Capacity	2 million inches (50 km) of travel	1,945 lbs	(882 kg)	1,945 lbs	(882 kg)
Each Bearing Dyn. Capacity	100 million inches (2540 km) of travel	525 lbs	(238 kg)	525 lbs	(238 kg)
Each Bearing Static Load Capacity		2,910 lbs	(1320 kg)	2,910 lbs	(1320 kg)
Maximum Belt Tensile Force		350 lbs	(159 kg)	350 lbs	(159 kg)
Maximum Carriage Thrust Force		230 lbs	(104 kg)	230 lbs	(104 kg)
Maximum Speed		118 in/sec	(3 m/sec)	118 in/sec	(3 m/sec)
Maximum Acceleration		386 in/sec ²	(9,8 m/sec ²)	772 in/sec ²	(19,6 m/sec ²)
d₁	Center to center distance (spread) between the two rails	3.660 in	(92,96 mm)	3.660 in	(92,96 mm)
d₂	Center to center distance (spacing) of the bearings on a single rail		-	3.290 in	(83,57 mm)
d_r	Center distance of the bearing to top of carriage plate surface	1.320 in	(33,53 mm)	1.320 in	(33,53 mm)

Other	For Two (2) & Four (4) Bearing Carriages
Table Material	Base, Carriage, End Plates, & Cover Plate - 6061 anodized aluminum
Linear Rail Material	Case Hardened Steel
Belt Properties	Black, 32 mm wide, Polyurethane, Steel reinforced belt
Drive Pulley Weight	0.39 lbs (0,18 kg)
Drive Pulley Diameter	1.128 in (28,65 mm)
Drive Lead	3.543 in (90,00 mm)
Belt Stretch - x Load (lbs or N)	0.00011 in/ft per lbs (0,00212 mm/m per N)
Unidirectional Repeatability	+/- 0.001 in (+/- 0,0254 mm)
Bidirectional Repeatability	+/- 0.004 in (+/- 0,1016 mm)
Position Accuracy (Belt)	< 0.010 in/ft (< 0,254 mm/300mm)
Orthogonality (multi-axis systems)	< 30 arc-seconds
Friction Coefficient	< 0.01
Breakaway Torque	< 75 oz-in (0,530 N-m)
Motor Mount	NEMA 23 & 34 Mounts, Metric Mounts, and Gearheads
Coupling	Two (2) different styles available
Waycover Material	Hypilon Polyester Bellows mounted to carriage & end plates

[More Information via the Web](#)

Standard Features

- ❑ Compact 6.0 inches (152 mm) wide by 2.953 inches (75 mm) tall
- ❑ Travel lengths from 6 inches (150 mm) to 108 inches (2740 meters)
- ❑ Threaded stainless steel inserts in carriage for load mounting
- ❑ Polyurethane belt with high strength steel tension members
- ❑ 0° F to +176° F (-18° C to +80° C) operating temperature
- ❑ Single screw belt tensioning with self locking thread
- ❑ Dynamic Load Capacity to 5,600 lbs (2540 kg)
- ❑ 2 rails, 4 or 6 bearing, 12 inch long carriage
- ❑ Recirculating linear ball bearing system
- ❑ Precision ground square rail design

180-CP0 series



Options

- ❑ End of travel (EOT) and home switches wired
- ❑ Adapter brackets for NEMA & Metric motors
- ❑ CAD drawings available via our Website
- ❑ Chrome plated linear bearings & rails
- ❑ Rotary incremental encoders
- ❑ NEMA 34 adapter bracket
- ❑ Power-off electric brakes
- ❑ Carriage adapter plates
- ❑ Planetary gearheads
- ❑ Motor couplings

180-CP1 series



180-CP2 series



180-WC1 series

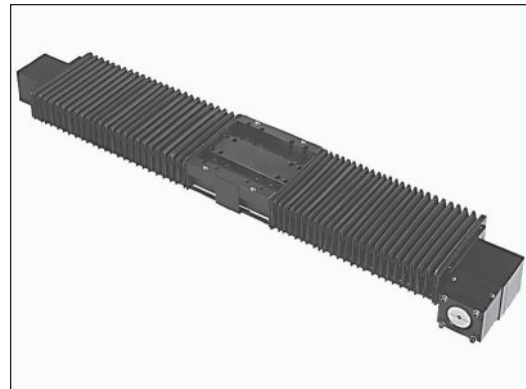

Specifications

Load Capacities		Four (4) Bearing Carriage		Six (6) Bearing Carriage	
Dynamic Horizontal	2 million inches (50 km) of travel	7,780 lbs	(3530 kgf)	11,670 lbs	(5290 kgf)
Dynamic Horizontal	100 million inches (2540 km) of travel	2,090 lbs	(948 kgf)	3,135 lbs	(1420 kgf)
Static Horizontal		11,640 lbs	(5280 kgf)	17,460 lbs	(7920 kgf)
Dynamic Roll Moment	2 million inches (50 km) of travel	1,025 ft-lbs	(1390 N-m)	1,540 ft-lbs	(2085 N-m)
Dynamic Roll Moment	100 million inches (2540 km) of travel	275 ft-lbs	(370 N-m)	410 ft-lbs	(555 N-m)
Static Roll Moment		1,830 ft-lbs	(2480 N-m)	2,750 ft-lbs	(3725 N-m)
Dyn. Pitch & Yaw Moment	2 million inches (50 km) of travel	2,160 ft-lbs	(2925 N-m)	2,235 ft-lbs	(3030 N-m)
Dyn. Pitch & Yaw Moment	100 million inches (2540 km) of travel	580 ft-lbs	(785 N-m)	600 ft-lbs	(810 N-m)
Static Pitch & Yaw Moment		3,860 ft-lbs	(5230 N-m)	3,980 ft-lbs	(5395 N-m)
Each Bearing Dyn. Capacity	2 million inches (50 km) of travel	1,945 lbs	(882 kgf)	1,945 lbs	(882 kgf)
Each Bearing Dyn. Capacity	100 million inches (2540 km) of travel	525 lbs	(238 kgf)	525 lbs	(238 kgf)
Each Bearing Static Load Capacity		2,910 lbs	(1320 kgf)	2,910 lbs	(1320 kgf)
Maximum Belt Tensile Force		350 lbs	(159 kg)	350 lbs	(159 kg)
Maximum Carriage Thrust Force		230 lbs	(104 kg)	230 lbs	(104 kg)
Maximum Speed		118 in/sec	(3 m/sec)	118 in/sec	(3 m/sec)
Maximum Acceleration		772 in/sec ²	(19,6 m/sec ²)	772 in/sec ²	(19,6 m/sec ²)
d₁	Center to center distance (spread) between the two rails	3.660 in	(92,96 mm)	3.660 in	(92,96 mm)
d₂	Center to center distance (spacing) of the bearings on a single rail	9.290 in	(235,97 mm)	4.645 in	(117,98 mm)
d_r	Center distance of the bearing to top of carriage plate surface	1.320 in	(33,53 mm)	1.320 in	(33,53 mm)

Other	For Four (4) & Six (6) Bearing Carriages
Table Material	Base, Carriage, End Plates, & Cover Plate - 6061 anodized aluminum
Linear Rail Material	Case Hardened Steel
Belt Properties	Black, 32 mm wide, Polyurethane, Steel reinforced belt
Drive Pulley Weight	0.39 lbs (0,18 kg)
Drive Pulley Diameter	1.128 in (28,65 mm)
Drive Lead	3.543 in (90,00 mm)
Belt Stretch - x Load (lbs or N)	0.00011 in/ft per lbs (0,00212 mm/m per N)
Unidirectional Repeatability	+/- 0.001 in (+/- 0,0254 mm)
Bidirectional Repeatability	+/- 0.004 in (+/- 0,1016 mm)
Position Accuracy (Belt)	< 0.010 in/ft (< 0,254 mm/300mm)
Orthogonality (multi-axis systems)	< 30 arc-seconds
Friction Coefficient	< 0.01
Breakaway Torque	< 75 oz-in (0,530 N-m)
Motor Mount	NEMA 23 & 34 Mounts, Metric Mounts, and Gearheads
Coupling	Two (2) different styles available
Waycover Material	Hypilon Polyester Bellows mounted to carriage & end plates

[More Information via the Web](#)

Standard Features

- ❑ 10.236 inches (260 mm) long carriage with two M5 slots for load mounting
- ❑ Compact 3.15 inches (80 mm) wide by 3.937 inches (100 mm) tall
- ❑ Travel lengths from 12 inches (300 mm) to 30 feet (9,1 meters)
- ❑ Rigid belt driven design with fully enclosed aluminum housing
- ❑ 0° F to +176° F (-18° C to +80° C) operating temperature
- ❑ Two screw belt tensioning with self locking threads
- ❑ Dynamic Load Capacity to 10,500 lbs (4763 kg)
- ❑ Recirculating linear ball bearing system
- ❑ Precision ground square rail design
- ❑ 1 rail with 2 bearing carriages

550 series (553 carriage)



- ❑ Two bearing carriage
- ❑ 10,500 lbs (4763 kg) dynamic load capacity
- ❑ 410 ft-lbs (556 N-m) dynamic roll moment
- ❑ Less expensive than the 555 carriage
- ❑ Large moment load capability

Options

- ❑ Angle brackets for multiple axis configurations
- ❑ End of travel (EOT) and home switches wired
- ❑ Adapter brackets for NEMA & Metric motors
- ❑ CAD drawings available via our Website
- ❑ Chrome plated linear bearings and rails
- ❑ Rotary incremental encoders
- ❑ Power-off electric brakes
- ❑ Base mounting brackets
- ❑ Carriage adapter plates
- ❑ Planetary gearheads
- ❑ Motor couplings

550 series (554 carriage)



- ❑ Two bearing carriage
- ❑ 10,500 lbs (4763 kg) dynamic load capacity
- ❑ 410 ft-lbs (556 N-m) dynamic roll moment
- ❑ Self lubricating linear bearings
- ❑ Large moment load capability

550 series (555 carriage)



- ❑ Two bearing carriage
- ❑ 9,120 lbs (4136 kg) dynamic load capacity
- ❑ 172 ft-lbs (233 N-m) dynamic roll moment
- ❑ Less audible noise than the 553 or 554 series
- ❑ Smoother than the 553 or 554 carriage
- ❑ Unique linear bearing design

Specifications

Load Capacities		553 & 554 Carriages		555 Carriage	
Dynamic Horizontal	2 million inches (50 km) of travel	12,650 lbs	(5740 kg)	12,650 lbs	(5740 kg)
Dynamic Horizontal	100 million inches (2540 km) of travel	3,400 lbs	(1540 kg)	3,400 lbs	(1540 kg)
Static Horizontal		19,000 lbs	(8620 kg)	19,000 lbs	(8620 kg)
Dynamic Roll Moment	2 million inches (50 km) of travel	560 ft-lbs	(760 N-m)	560 ft-lbs	(760 N-m)
Dynamic Roll Moment	100 million inches (2540 km) of travel	150 ft-lbs	(200 N-m)	150 ft-lbs	(200 N-m)
Static Roll Moment		790 ft-lbs	(1070 N-m)	790 ft-lbs	(1070 N-m)
Dyn. Pitch & Yaw Moment	2 million inches (50 km) of travel	1,710 ft-lbs	(2320 N-m)	1,710 ft-lbs	(2320 N-m)
Dyn. Pitch & Yaw Moment	100 million inches (2540 km) of travel	460 ft-lbs	(625 N-m)	460 ft-lbs	(625 N-m)
Static Pitch & Yaw Moment		1,775 ft-lbs	(2406 N-m)	845 ft-lbs	(1145 N-m)
Each Bearing Dyn. Capacity	2 million inches (50 km) of travel	6,325 lbs	(2870 kg)	6,325 lbs	(2870 kg)
Each Bearing Dyn. Capacity	100 million inches (2540 km) of travel	1,700 lbs	(770 kg)	1,700 lbs	(770 kg)
Each Bearing Static Load Capacity		9,500 lbs	(4310 kg)	9,500 lbs	(4310 kg)
Maximum Belt Tensile Force		675 lbs	(306 kg)	675 lbs	(306 kg)
Maximum Carriage Thrust Force		475 lbs	(215 kg)	475 lbs	(215 kg)
Maximum Speed		118 in/sec	(3 m/sec)	197 in/sec	(5 m/sec)
Maximum Acceleration		1,930 in/sec ²	(49,0 m/sec ²)	1,930 in/sec ²	(49,0 m/sec ²)
d₂	Center to center distance (spacing) of each bearing on a single rail	3.876 in	(98,4 mm)	3.876 in	(98,4 mm)
d_r	Center distance of the bearing to top of carriage plate surface	1.508 in	(38,3 mm)	1.626 in	(41,3 mm)

Other	553, 554 & 555 Carriages
Table Material	Base Extrusion, Carriage, & End Plates - 6061 anodized aluminum
Linear Rail Material	Case Hardened Steel
Belt Properties	Black, 50 mm wide, Polyurethane, Steel reinforced belt
Drive Pulley Weight	1.500 lbs (0,68 kg)
Drive Pulley Diameter	2.569 in (65,25 mm)
Drive Lead	8.071 in (205,00 mm)
Belt Stretch - x Load (lbs or N)	0.00006 in/ft per lbs (0,00114 mm/m per N)
Unidirectional Repeatability	+/- 0.001 in (+/- 0,0254 mm)
Bidirectional Repeatability	+/- 0.004 in (+/- 0,1016 mm)
Position Accuracy (Belt)	< 0.010 in/ft (< 0,254 mm/300mm)
Orthogonality (multi-axis systems)	< 60 arc-seconds
Friction Coefficient	< 0.01
Breakaway Torque	< 16 lb-in (1,808 N-m)
Motor Mount	NEMA 34 & 42 Mounts, Metric Mounts, and Gearheads
Coupling	Two (2) different styles available

[More Information via the Web](#)

Standard Features - 300 series

- ❑ Worm gear drive
- ❑ NEMA 23 & 34 motor mounts
- ❑ Standard & Precision versions
- ❑ 45, 90, & 180:1 gear reductions
- ❑ Load capacity to 225 lbs (102 kg)
- ❑ 30 revs/sec maximum input speed
- ❑ 10 arc-sec unidirectional repeatability
- ❑ 6, 8, 10, & 12 inch table top diameters
- ❑ CAD drawings available via our Website
- ❑ 0.75 inch (19 mm) diameter through hole
- ❑ English & Metric inserts for load mounting

Standard Features - 400 series

- ❑ Worm gear drive
- ❑ NEMA 34 motor mount
- ❑ Standard & Precision versions
- ❑ English inserts for load mounting
- ❑ 9 revs/sec maximum input speed
- ❑ Load capacity to 1,000 lbs (453 kg)
- ❑ 12 arc-sec unidirectional repeatability
- ❑ 5.48 inch (139 mm) table top diameter
- ❑ CAD drawings available via our Website
- ❑ 4.5 inch (114 mm) diameter through hole
- ❑ 30, 90, 180, 270, & 360:1 gear reductions

300 series



400 series



Specifications

Load Capacities	300 series ⁽¹⁾	400 series ⁽¹⁾
Dynamic Horizontal (1 million revs)	225 lbs (102 kg)	1000 lbs (453 kg)
Dynamic Inverted (1 million revs)	100 lbs (45 kg)	1000 lbs (453 kg)
Static Horizontal	250 lbs (113 kg)	1000 lbs (453 kg)
Dynamic Moment (1 million revs)	20 ft-lbs (27 N-m)	225 ft-lbs (305 N-m)
Static Moment	25 ft-lbs (34 N-m)	250 ft-lbs (339 N-m)
Maximum Input Speed	30 rev/sec	9 rev/sec
Maximum Input Acceleration	75 rev/sec ²	50 rev/sec ²

Other	300 series	400 series						
Table Material	Base & Table Top - 6061 black anodized aluminum							
Worm Wheel Type	Bronze (AGMA - class 10)							
Worm Gear Type	Steel (AGMA - class 10)							
Duty Cycle	60 %							
(gear ratio)	45:1	90:1	180:1	30:1	90:1	180:1	270:1	360:1
Maximum Table Top Speed	40 rpm	20 rpm	10 rpm	18 rpm	6 rpm	3 rpm	2 rpm	1.5 rpm
Worm Gear Efficiency	50 %	60 %	70 %	50 %	60 %	60 %	60 %	60 %
Worm Gear Inertia (oz-in ²)	0.03	0.03	0.03	0.10	0.10	0.13	0.16	0.19
Accuracy	< 150 arc-sec			< 180 arc-sec				
Unidirectional Repeatability	< 10 arc-sec			< 12 arc-sec				
Bidirectional Repeatability	< 40 arc-sec			< 42 arc-sec				
Backlash	< 30 arc-sec			< 30 arc-sec				
Runout (vertical runout)	Standard < 0.003 in (0,076 mm) ⁽²⁾	< 0.002 in (0,05 mm) ⁽³⁾						
	Precision < 0.001 in (0,025 mm) ⁽²⁾							
Concentricity (radial runout)	Standard < 0.003 in (0,076 mm) ⁽⁴⁾	< 0.002 in (0,05 mm) ⁽⁵⁾						
	Precision < 0.001 in (0,025 mm) ⁽⁴⁾							
Wobble (axis runout)	Standard < 80 arc-sec ⁽⁶⁾	< 60 arc-sec ⁽⁶⁾						
	Precision < 40 arc-sec ⁽⁶⁾							
Breakaway Torque	< 20 oz-in (0,141 N-m)			< 60 oz-in (0,424 N-m)				

Footnotes:

- (1) Dynamic load capacities & life are limited by the stresses exerted upon the worm gear assembly.
- (2) Measured at 6 inches (152,4 mm) from table top center. Total indicator runout.
- (3) Measured at 5.5 inches (139,7 mm) from table top center. Total indicator runout.
- (4) Measured at 0.75 inches (19,1 mm) from table top center. Total indicator runout.
- (5) Measured at 4.5 inches (114,3 mm) from table top center. Total indicator runout.
- (6) Based on the centerline of the table top.

[More Information via the Web](#)

LINTECH shafts, shaft assemblies, linear bearings, pillow blocks and carriage assemblies are used in many different applications requiring mechanical motion. These components are utilized with air cylinders, hydraulic actuators, lead screws, rack & pinion systems, belt & pulleys, chain & sprockets, as well as in manual positioning systems. **LINTECH** individual shafts or SA shaft assemblies, along with individual linear bearings or pillow blocks, are typically used when a designer wishes to spread apart the shafts or SA shaft assemblies and make a custom carriage assembly. The TRSA shaft assemblies and TRCA carriage assemblies are utilized together when ease of installation is of essence.

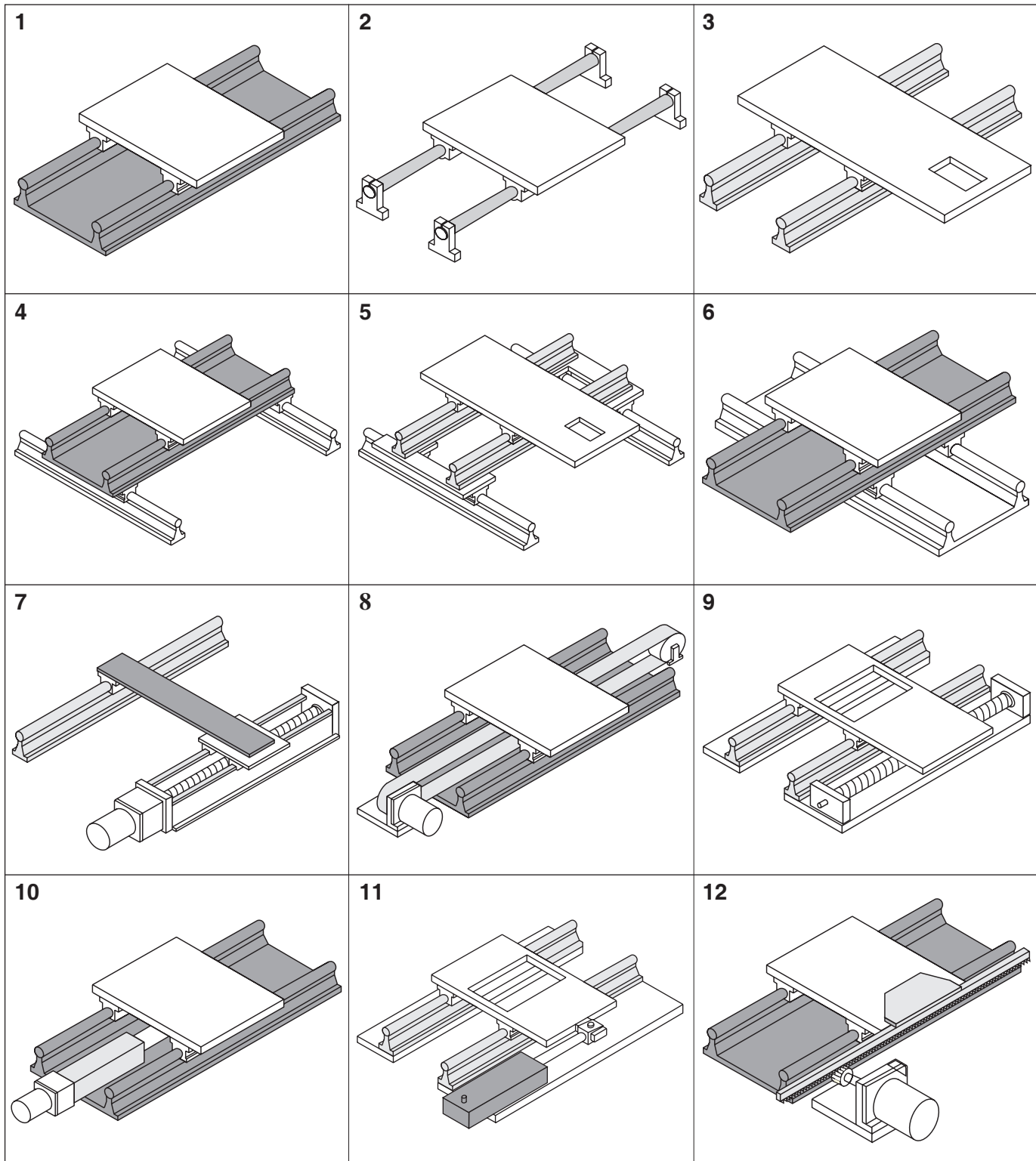

LINTECH can provide adapter plates and vertical brackets to facilitate the construction of X-Y, X-Z, and X-Y-Z multi-axis configurations. There are hundreds of possible configurations available. See below for some of the more common systems. *LINTECH* has experience dealing with multiple axis configurations. Sometimes different standard table series can be mounted to form a custom system. Other times, a custom assembly can be created. Contact *LINTECH* for more information.

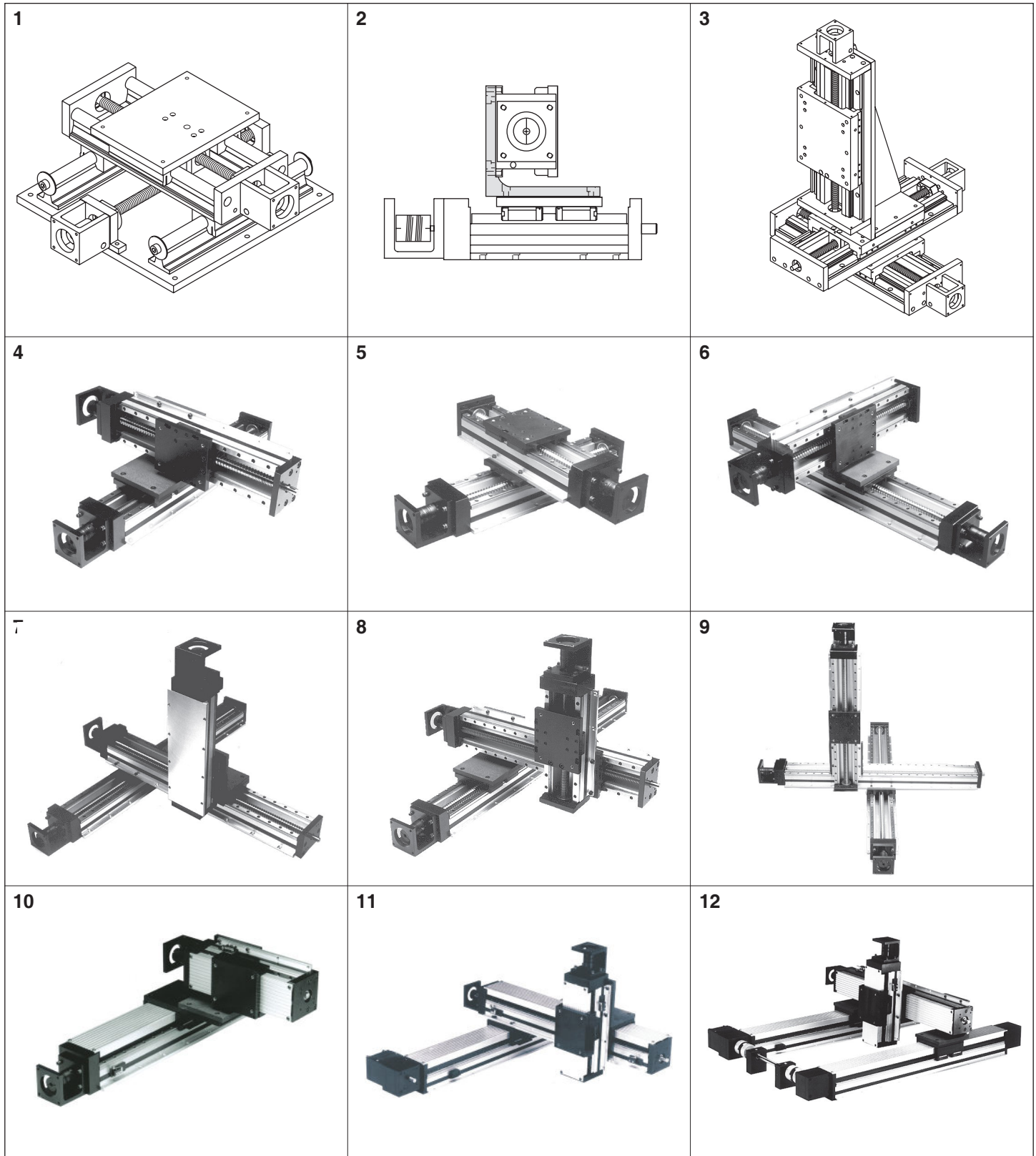

Custom Systems

LINTECH has been manufacturing custom positioning assemblies and systems for use in a wide variety of applications for over 46 years. Some of these custom systems have been simple modifications of carriage assemblies, special base mounting hole patterns, non-standard travel lengths, specific motor mount brackets, or different accessories such as couplings, encoders, or waycovers.

Other more involved custom systems have been:

- * 30 x 30 x 30 foot X-Y-Z inspection stations
- * 60 foot part placement machines
- * 5,000 pound load capacity assembly stations.
- * vacuum or wash down rated
- * 9 axis special assembly machines

All of these custom systems were successful by following a simple approach.

Review, fill out, and provide all the information on the application guide shown on the next page. Providing us with all, or as much detail up front, can lead to the successful completion of a custom system. Then submit this information to **LINTECH** and we will review the data, to see if it is within our capabilities to manufacture.

Some of the more important information to provide us follows:

Budget will become extremely important in our evaluation process with you. With our many years of experience building custom systems we will be able to determine if the required performance you are seeking is possible within your budget.

Accuracy or Repeatability will make a big difference in the cost of a custom system. The accuracy of 0.0002 inches over 48 inches of travel will cost a whole lot more than a repeatability of 0.0002 inches over the same 48 inches of travel.

Load Weight will have an impact on the linear bearing, drive assembly, and structure that we would design for the custom system. Providing a realistic estimated of load weight (along with any other potential external forces), without too much of a safety factor will help select the proper custom positioning components. We will use the proper safety factors based on your application details.

Required System Life will also affect the selection of the proper components for the system.

System Speeds may affect the cost of a custom system if larger, more expensive components are required to meet the application needs. Providing us with a realistic target speed helps create a successful custom system.

Application Sketch (or diagram) can help minimize the time for us to respond to your request.

Other Details such as waycovers, motor mounts, or carriage size may not seem like key items to mention. However, providing us with as much information on the application requirements will lead to the successful completion of a custom system.

[More Information via the Web](#)

Design Considerations

Application Guide

Name _____ Date _____

Company _____ State _____

Phone (____) _____ Email _____

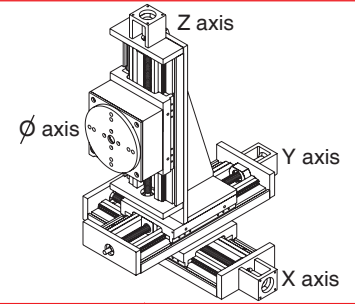

System Requirements _____ **Budget (per system)** _____

Axis	X	Y	Z	Ø	Axis	X	Y	Z	Ø
Load Dimensions length x width (in or mm)					Maximum Accel (in/sec ² or m/sec ²)				
Load Weight (lbs or kg)					Duty Cycle (%)				
Travel Length (in or mm)					Table Life (millions of inches or Km)				
Repeatability (in or mm)					Motor Frame Size (NEMA 23, 34, 42, other)				
Accuracy (Overall - in or mm)					Limit Switch Type (mech, reed, hall, prox)				
Maximum Speed (in/sec or mm/sec)					Waycovers (Yes or No)				
Most Difficult Move Profile	Distance (in or mm)				Encoder (linear, rotary, & resolution)				
	Time (sec)					Power-off Brake (Yes or No)			

Special Requirements

- High Temperature
- Clean Room
- Maximum Smoothness
- Motor Wrap
- Vacuum Rated
- High Moisture
- Low Audible Noise
- Other (explain below)

Moment Loads

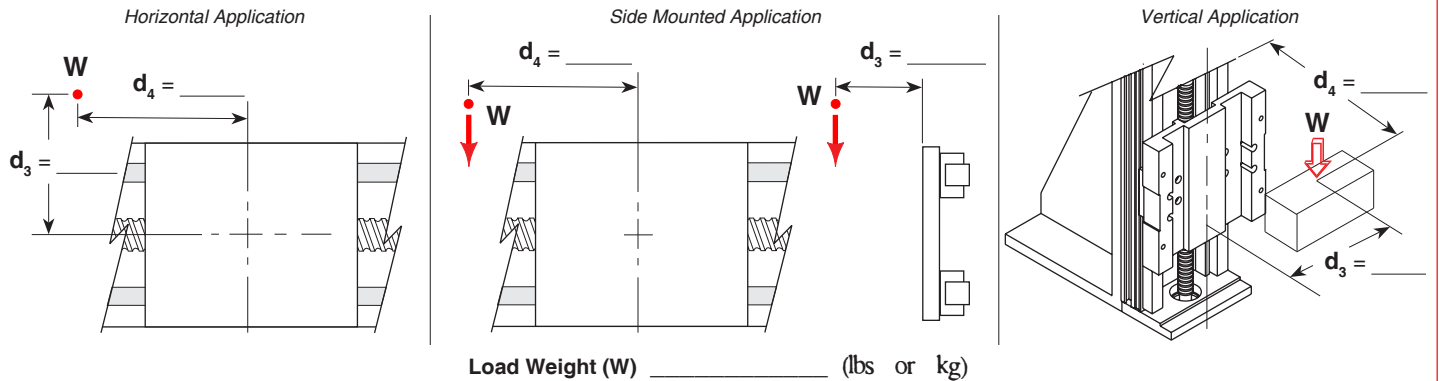

Application Details

Custom Positioning Systems



Dual carriages individually driven by two motors on same base

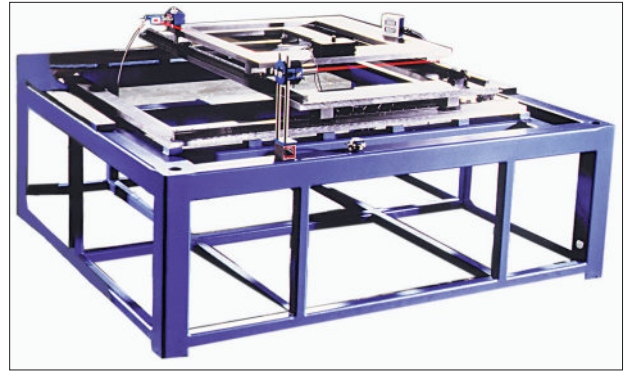

X-Y open frame inspection station with a steel support structure

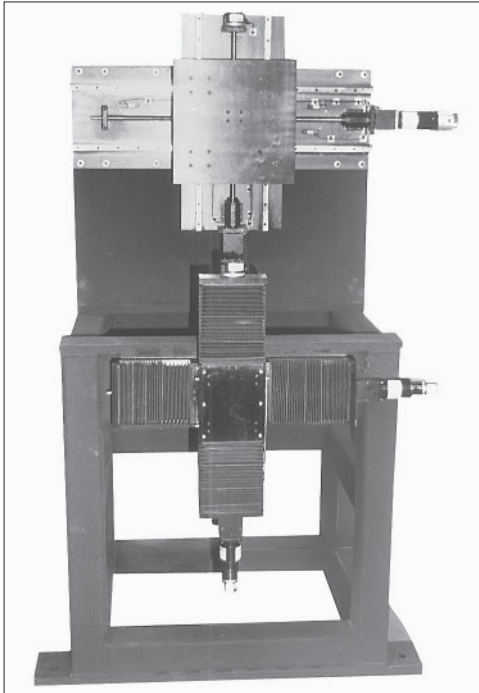

Two individual X-Y axes for laser cutting process supported by steel structure



X-Y-Z automated assembly system with aluminum support structure

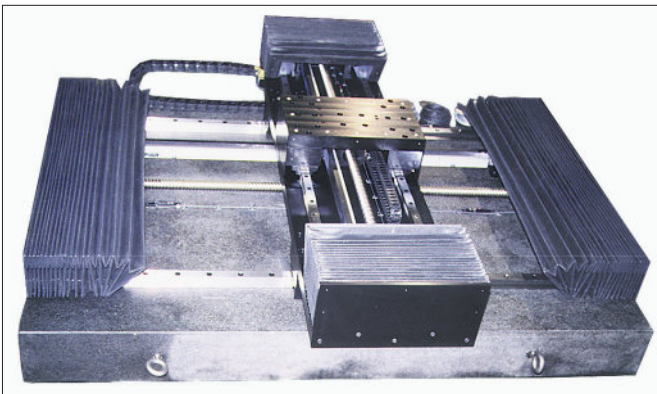

High speed X-Y laser marking assembly with a granite support structure



X-Y axis water jet cutting process with open frame steel support structure

Custom Positioning Systems



X-Y chemical coating process with open frame aluminum structure



X axis machining station with steel support structure

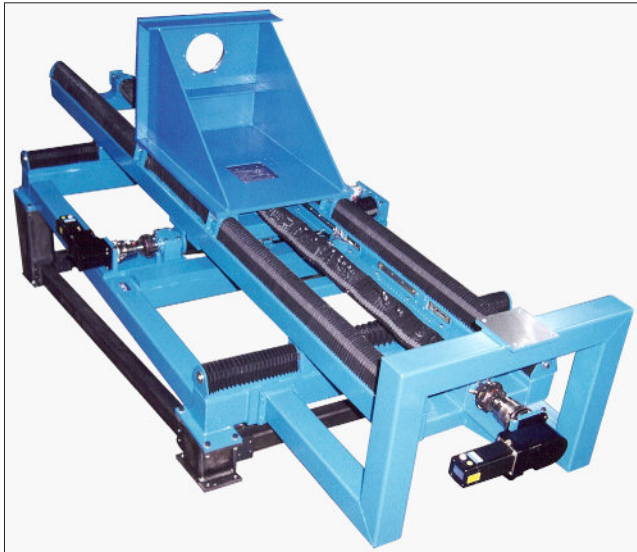

X-Y machine assembly process mounted to steel support structure



Belt driven long travel X-Y-Z inspection station with aluminum support structure



X-Y belt driven infrared inspection station supported by movable aluminum structure

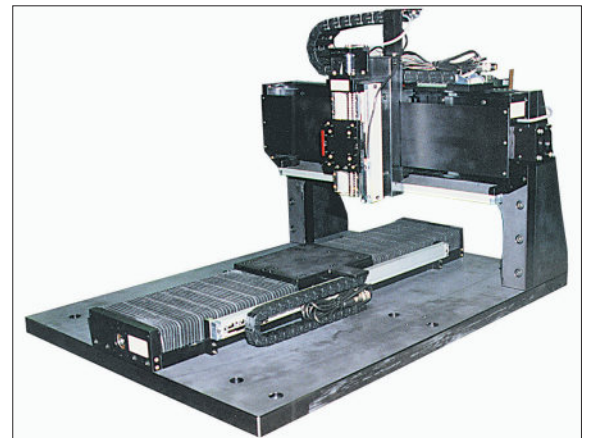

High accuracy X-Z vision inspection station mounted on a steel sub plate

Unit Conversions

Torque Conversions

Present Units	Convert To	Multiply By
Gram-centimeters	newton-meters	0.0000981
Gram-centimeters	ounce-inches	0.0138874
Gram-centimeters	pound-inches	0.000868
Gram-centimeters	pound-feet	0.0000723
Newton-meters	gram-centimeters	10,197.162
Newton-meters	ounce-inches	141.612
Newton-meters	pound-inches	8.85
Newton-meters	pound-feet	0.73756
Ounce-inches	gram-centimeters	72.0077
Ounce-inches	newton-meters	0.007062
Ounce-inches	pound-inches	0.0625
Ounce-inches	pound-feet	0.005208
Pound-inches	gram-centimeters	1,152.0
Pound-inches	newton-meters	0.11299
Pound-inches	ounce-inches	16.0
Pound-inches	pound-feet	0.08333
Pound-feet	gram-centimeters	13,825.5
Pound-feet	newton-meters	1.3558
Pound-feet	ounce-inches	192.0
Pound-feet	pound-inches	12.0

Distance Conversions

Present Units	Convert To	Multiply By
Arc-minutes	degrees	0.016666
Arc-seconds	degrees	0.000277
Centimeters	inches	0.3937
Centimeters	feet	0.03280
Centimeters	microns	10,000.0
Degrees	arc-minutes	60.0
Degrees	arc-seconds	3,600.0
Degrees	radians	0.017453
Feet	centimeters	30.48
Feet	meters	0.3048
Inches	centimeters	2.54
Inches	Km	0.0000254
Inches	meters	0.0254
Inches	microns	25,400.0
Inches	millimeters	25.4
Km	inches	39,370.0
Meters	feet	3.2808
Meters	inches	39.37
Meters	microns	1,000,000.0
Microns	centimeters	0.0001
Microns	inches	0.00003937
Microns	meters	0.000001
Microns	millimeters	0.001
Millimeters	inches	0.03937
Millimeters	microns	1,000.0
Radians	degrees	57.295779

Inertia Conversions

Present Units	Convert To	Multiply By
Gram-cm ²	ounce-inches ²	0.00546745
Gram-cm ²	ounce-inch-sec ²	0.000014161
Gram-cm ²	pound-inches ²	0.000341716
Gram-cm ²	pound-inch-sec ²	0.000000885
Gram-cm ²	pound-feet-sec ²	0.000000074
Ounce-inches ²	gram-cm ²	182.901
Ounce-inches ²	ounce-inch-sec ²	0.00259008
Ounce-inches ²	pound-inches ²	0.0625
Ounce-inches ²	pound-inch-sec ²	0.00016188
Ounce-inches ²	pound-feet-sec ²	0.00001349
Ounce-inch-sec ²	gram-cm ²	70,615.4
Ounce-inch-sec ²	ounce-inches ²	386.0
Ounce-inch-sec ²	pound-inches ²	24.13045
Ounce-inch-sec ²	pound-inch-sec ²	0.0625
Ounce-inch-sec ²	pound-feet-sec ²	0.00520833
Pound-inches ²	gram-cm ²	2,926.41
Pound-inches ²	ounce-inches ²	16.0
Pound-inches ²	ounce-inch-sec ²	0.0414413
Pound-inches ²	pound-inch-sec ²	0.00259008
Pound-inches ²	pound-feet-sec ²	0.00021584
Pound-inch-sec ²	gram-cm ²	1,129,850.0
Pound-inch-sec ²	ounce-inches ²	6,177.4
Pound-inch-sec ²	ounce-inch-sec ²	16.0
Pound-inch-sec ²	pound-inches ²	386.0
Pound-inch-sec ²	pound-feet-sec ²	0.0833333
Pound-feet-sec ²	gram-cm ²	13,558,200.0
Pound-feet-sec ²	ounce-inches ²	74,128.9
Pound-feet-sec ²	ounce-inch-sec ²	192.0
Pound-feet-sec ²	pound-inches ²	4,633.06
Pound-feet-sec ²	pound-inch-sec ²	12.0

Load Conversions

Present Units	Convert To	Multiply By
Grams	newtons	0.009806
Grams	ounces	0.03528
Grams	pounds	0.002204
Kilograms	pounds	2.2046
Newtons	grams	101.971
Newtons	ounces	3.59692
Newtons	pounds	0.224808
Ounces	grams	28.3495
Ounces	newtons	0.27802
Ounces	pounds	0.0625
Pounds	grams	453.592
Pounds	kilograms	0.45359
Pounds	newtons	4.44824
Pounds	ounces	16.0
Pounds	tons	0.0005
Tons	pounds	2,000.0

Terms of Sale

To Order

Any standard, or custom, product from *LINTECH* may be ordered by mail, email, on-line, phone, or fax from an Automation Specialist in your area. To obtain the name of your local Automation Specialist call:

LINTECH[®]
1845 Enterprise Way
Monrovia, CA 91016

Toll Free: (800) 435 - 7494
Phone: (626) 358 - 0110
Fax: (626) 303 - 2035

Web Site: www.LintechMotion.com
E-Mail: Lintech@LintechMotion.com

All required options should be reviewed using the part numbering guide for each model series. Your local Automation Specialist or factory personnel can assist you with any questions you may have.

Delivery

All shipping promises are made in good faith. Any shipping dates appearing on acknowledgments of orders or given to a customer in any other manner are approximate. Where the customer delays in supplying information necessary to proceeding with an order, the date of shipment may be extended accordingly. Standard products from *LINTECH* are usually available for delivery within 1 to 6 weeks of receipt of a purchase order. However, component shortages, labor disputes, or any other unforeseen circumstance may delay the delivery of an order. *LINTECH* shall not be held liable under any circumstance. All products are shipped F.O.B. Monrovia, CA. *LINTECH* packages all standard and custom products carefully. However, *LINTECH* is not liable for damage incurred during shipment. Contact the carrier immediately if damage to a package or shipment is noticed upon receipt of such shipment.

Payment Terms

Unless otherwise specified, payment shall be made by C.O.D, credit card (AMEX, Visa, or Master Card), or net thirty (30) days (pending credit approval) from date of shipment of the items purchased hereunder in U.S. currency. *LINTECH* reserves the right to require deposit payments on non-standard items, customs, or product built to Buyer's designs or specifications. Amounts not timely paid shall bear interest at the rate of 1.5% for each month or a portion thereof that Buyer is late in making payments. No responsibility is assumed by *LINTECH* for damages arising from delivery delays, fires, strikes, material shortages, accidents, or any other cause whatsoever, and purchase orders are accepted subject only to these conditions irrespective of statements or stipulations on purchase orders.

Minimum Order Amount

LINTECH requires a minimum of \$30 List Price U.S. currency on all orders.

Warranty

All *LINTECH* products are guaranteed to be free from defects in material and workmanship, under normal use, for a period of one year after date of shipment. This warranty covers the repair or replacement of a product when it is sent prepaid to *LINTECH*. *LINTECH* does not assume liability for installation, abuse, alteration, insufficient application data provided for a design, or misuse of any positioning system. Products furnished by *LINTECH*, but not manufactured by *LINTECH* (motors, gearheads, encoders, amplifiers, etc....), are subject to the manufacturers standard warranty terms and conditions.

Returns

Any product requiring a return to *LINTECH* (for warranty or non-warranty repair) requires pre-approval from the factory prior to shipment. Contact the customer service department at (800) 435-7494 in order to obtain a RMA (Return Materials Authorization) number. At that time, please have your system Model & Serial numbers available, along with the reason for the return. The RMA number should be clearly marked on the returned package label and your packing list, or shipping document. Return product freight prepaid in its original package or one with comparable protection. *LINTECH* will not accept return shipments sent freight collect. Product damage incurred during return shipment, from poor packaging, will not be warranted by *LINTECH*. Keeping original packing materials is recommended until initial inspection and testing is completed.

Dimensions and Product Changes

Published dimensions shown in *LINTECH* catalogs are known to be accurate at time of printing. *LINTECH* shall not be held liable, under any circumstances, for any wrongly documented dimension or specification. Changes in design are made whenever *LINTECH* believes its products will improve by the change. No obligation to incorporate these changes in units manufactured prior to a change will be assumed.

Cancellations

All items entered for production and on which a cancellation is requested shall be paid for on the basis of actual cost of labor, materials, and supplies applied to the production of such items plus proper overhead expenses determined in accordance with good accounting practice, plus 25% of the total of such cost and expenses; provided that such cost and expense plus 25% shall in no case exceed 100% of the quoted price of original order. Upon cancellation, *LINTECH* may dispose of materials used in the manufacture of cancelled order as it sees fit.

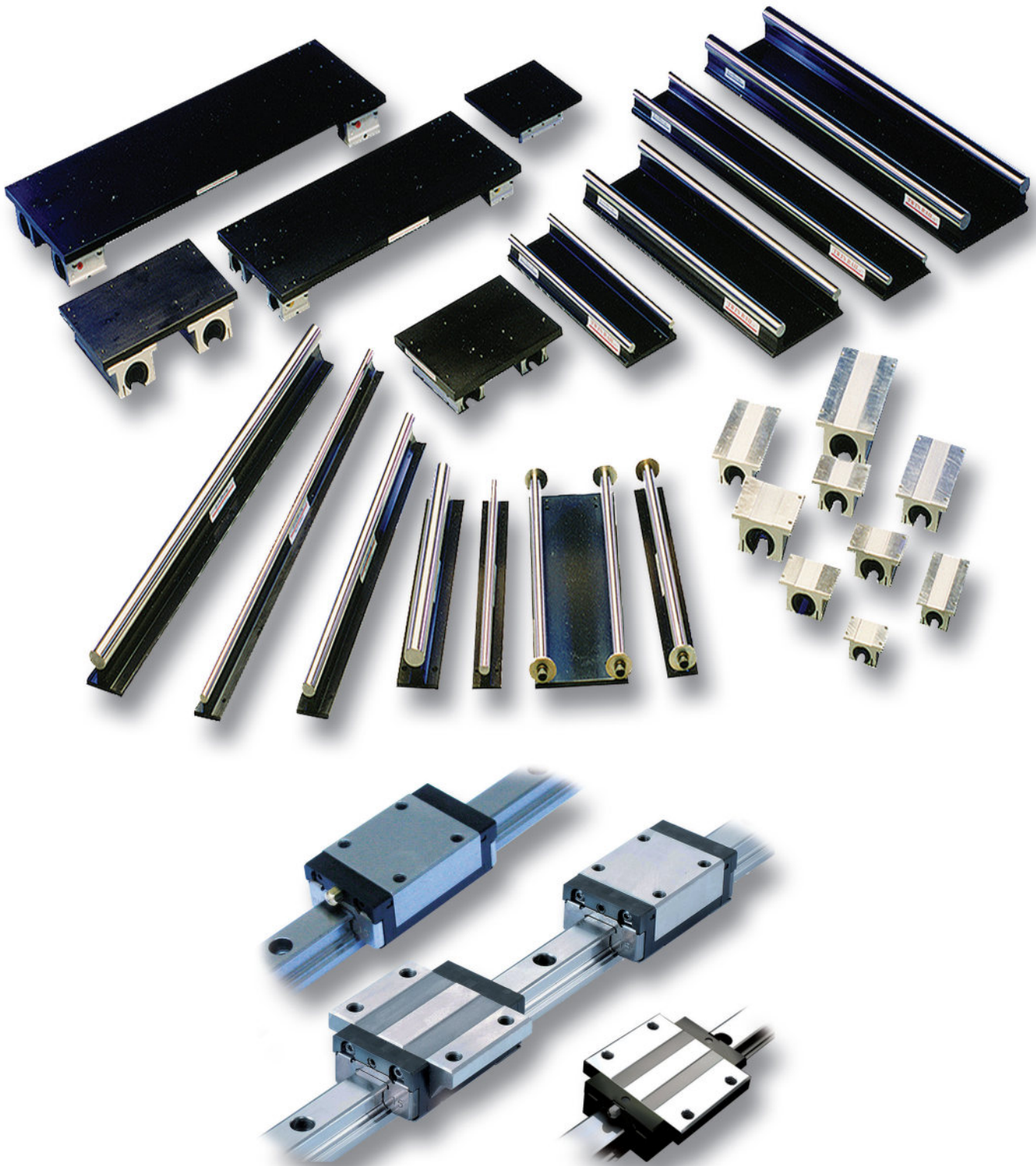

1845 Enterprise Way
Monrovia, CA. 91016
Phone: (800) 435 - 7494
(626) 358 - 0110
Fax: (626) 303 - 2035

Web Site: www.LintechMotion.com
E-Mail: Lintech@LintechMotion.com

YOUR LOCAL AUTOMATION SPECIALIST:

